

**MICROZED V3.5 BOARD**

S.&A.S. Ltd.  
 Jieh Chouf  
 Lebanon  
 support@sascontrollers.com

MICROZED V3.5 WIRING DIAG: DOOR INFO

DC Contactors

Size B	FCSM No. -	DWG No. A350AC2SV1W2_Ips_ContDC.Sch	Rev 1
Scale -	Sheet		2 of 14

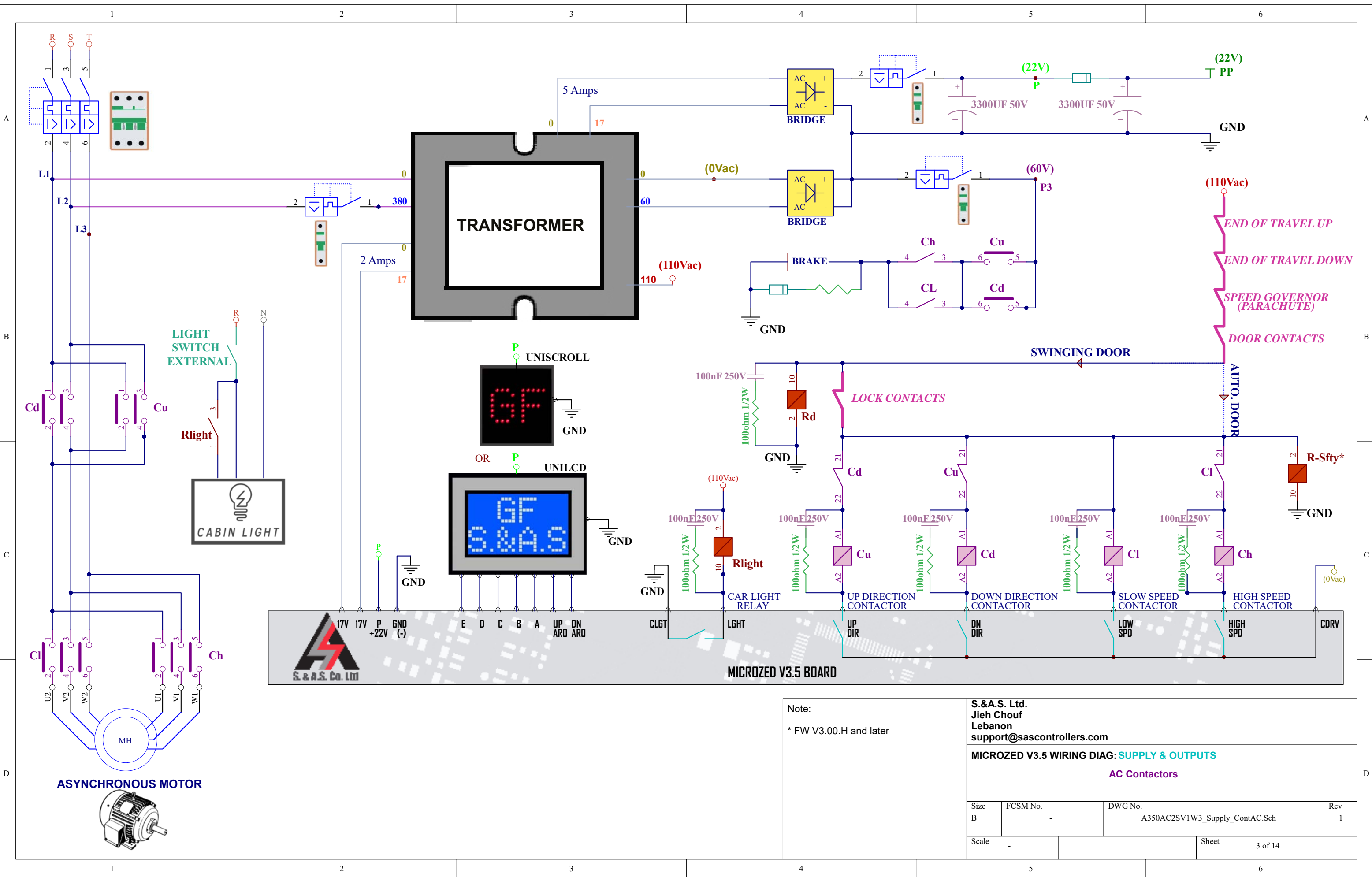

Note:  
\* FW V3.00.H and later

S.&A.S. Ltd.  
Jieh Chouf  
Lebanon  
support@sascontrollers.com

**MICROZED V3.5 WIRING DIAG: SUPPLY & OUTPUTS**  
**AC Contactors**

Size B	FCSM No. -	DWG No. A350AC2SV1W3_Supply_ContAC.Sch	Rev 1
Scale -	Sheet 3 of 14		



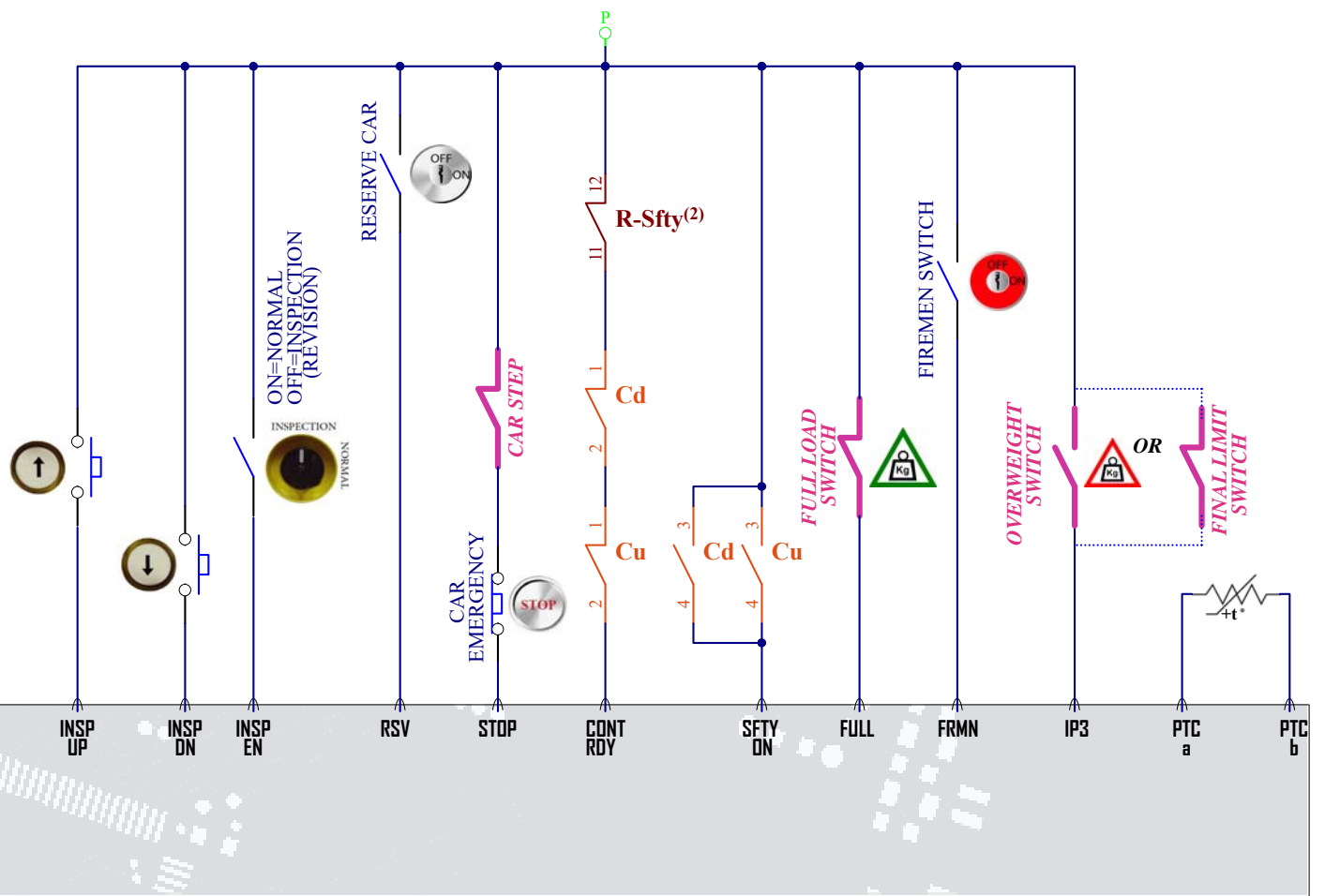
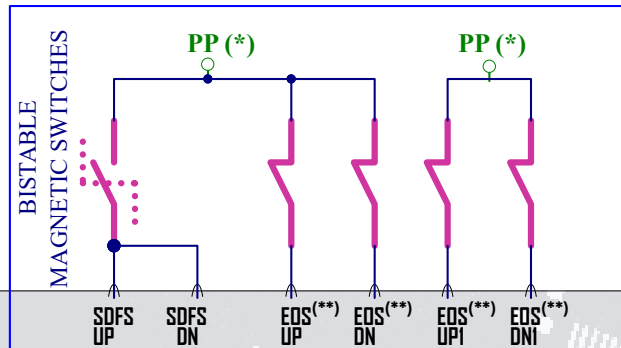
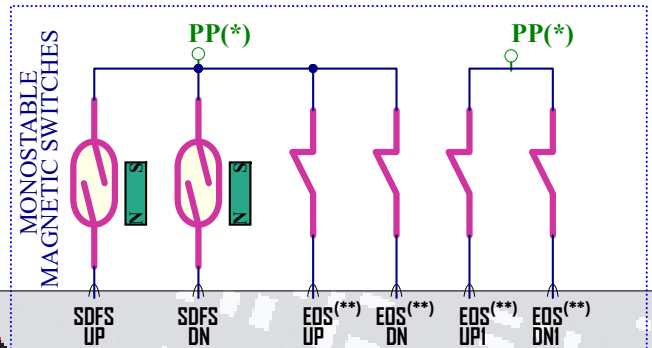
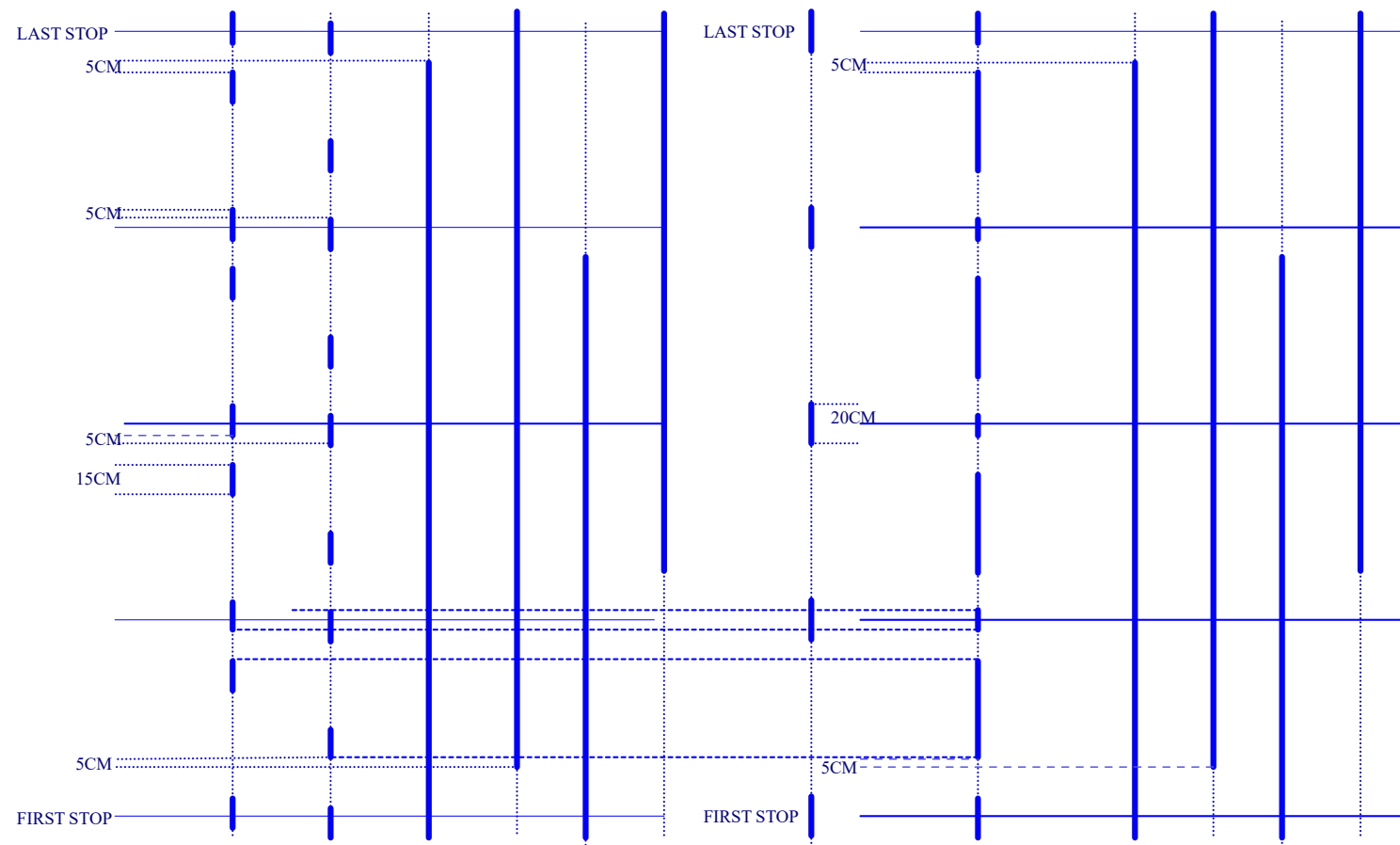

MICROZED V3.5 BOARD

Note:  
 (1): DZ is recommended for automatic door.  
 (\*): "PP" only for magnetic switches  
 (\*\*): Enabled when Dip switch 2 is OFF  
 (2) FW V3.00.H and later

S.&A.S. Ltd.  
 Jieh Chouf  
 Lebanon  
 support@sascontrollers.com

MICROZED V3.5 WIRING DIAG: **INPUTS/DOOR INFO**  
**AC Contactors**

Size B	FCSM No.	DWG No. A350AC2SV1W5_DOOR-INFO.Sch	Rev
Scale	Sheet 5 of 14		

1 2 3 4 5 6

A

B

C

D

A

B

C

D

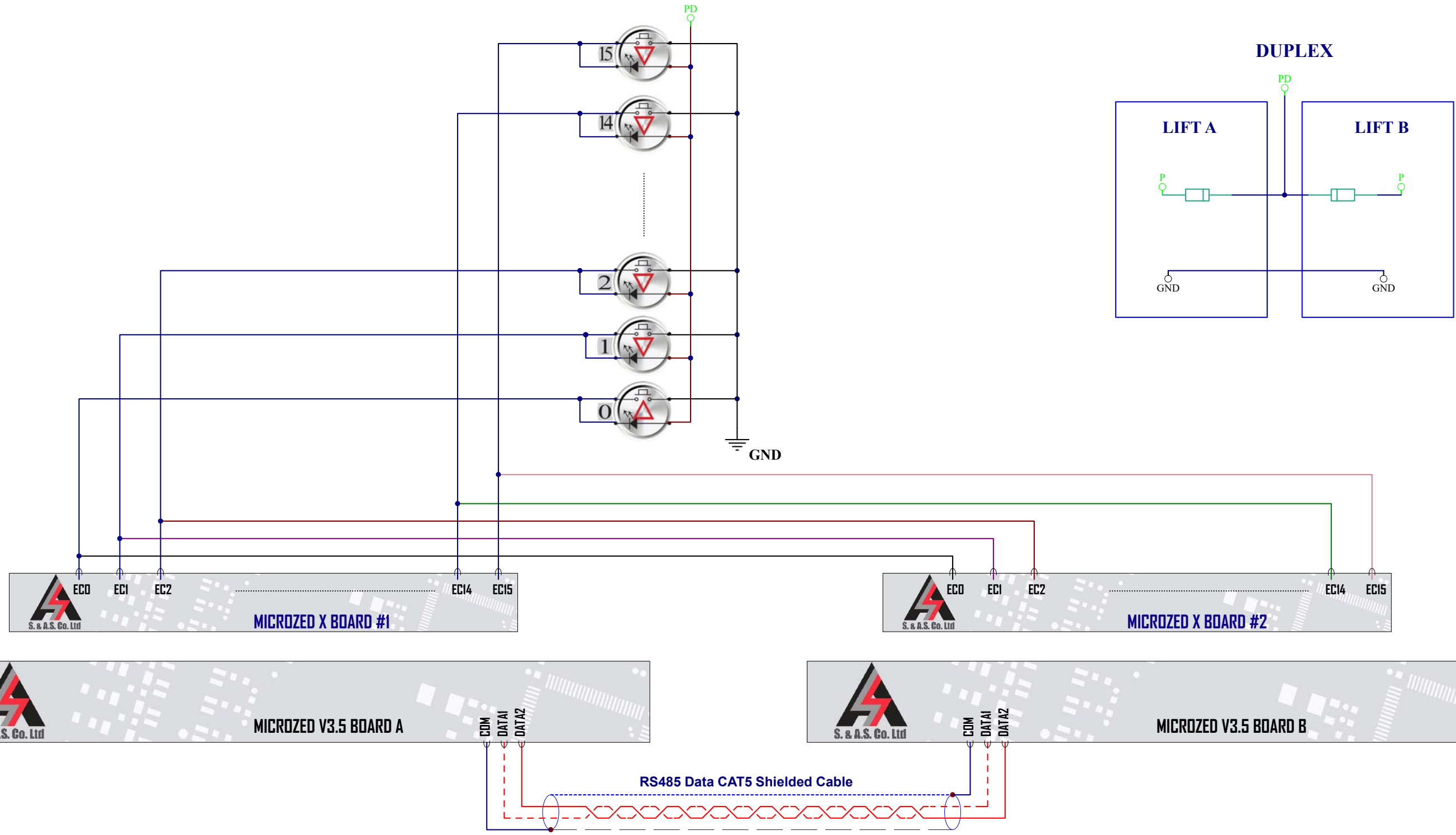

S.&A.S. Ltd.  
 Jieh Chouf  
 Lebanon  
 support@sascontrollers.com

**MICROZED V3.5 WIRING DIAG: LANDING CALLS FOR DUPLEX ON EXTENSION**

Size B	FCSM No. -	DWG No. A350AC2SV1W6_CALLS-Duplex.Sch	Rev 1
Scale -	Sheet 6 of 14		

1 2 3 4 5 6

LAND CALLS DOWN

LAND CALLS UP

CAR CALLS

P OR PD IF DUPLEX

P OR PD IF DUPLEX

P

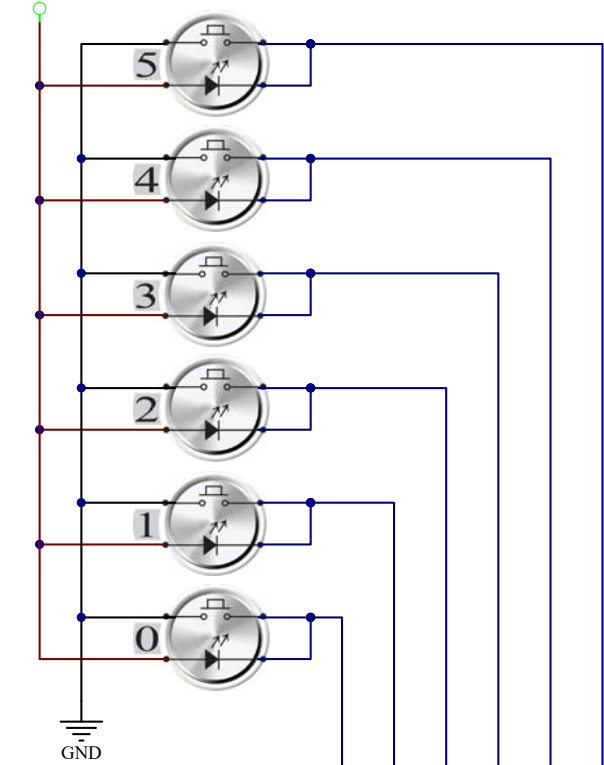
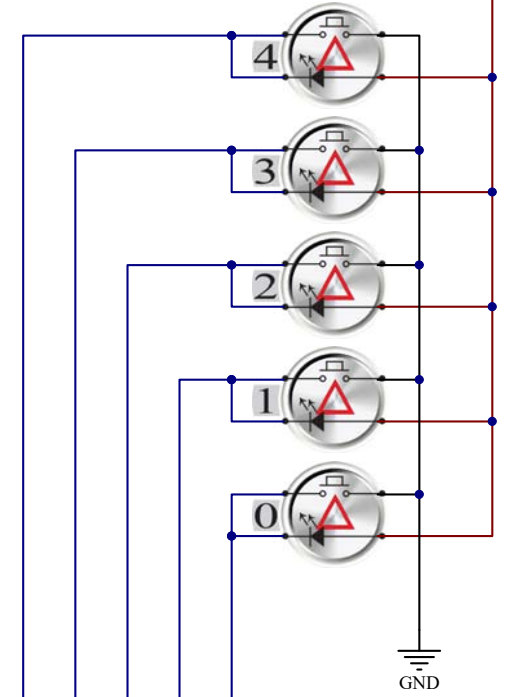
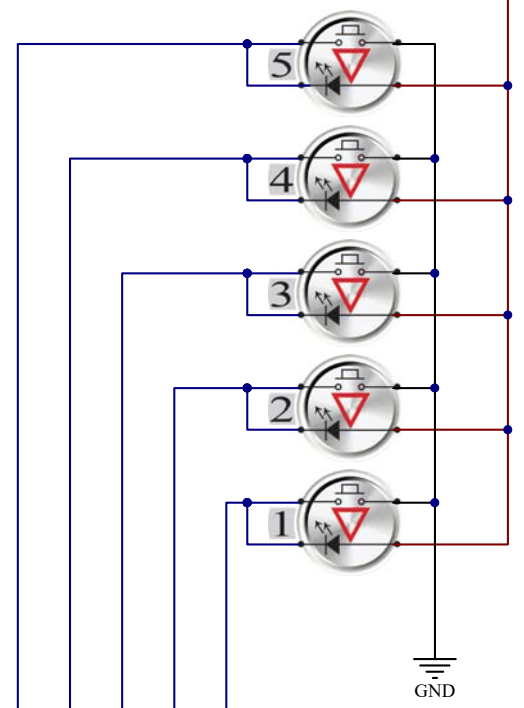

**S. & A.S. Co. Ltd**

**MICROZED V3.5 BOARD**

CT 15 CT 14 CT 13 CT 12 CT 11 CT 10 CT 9 CT 8 CT 7 CT 6 CT 5 CT 4 CT 3 CT 2 CT 1 CT 0

**S.&A.S. Ltd.**  
**Jieh Chouf**  
**Lebanon**  
**support@sascontrollers.com**  
**MICROZED V3.5 WIRING DIAG: CALLS W/O EXTENSION**  
**FULL COLLECTIVE - 6 STOPS**

Size B	FCSM No.	DWG No.	Rev 1
Scale	Sheet 7 of 14		

**CAR CALLS**

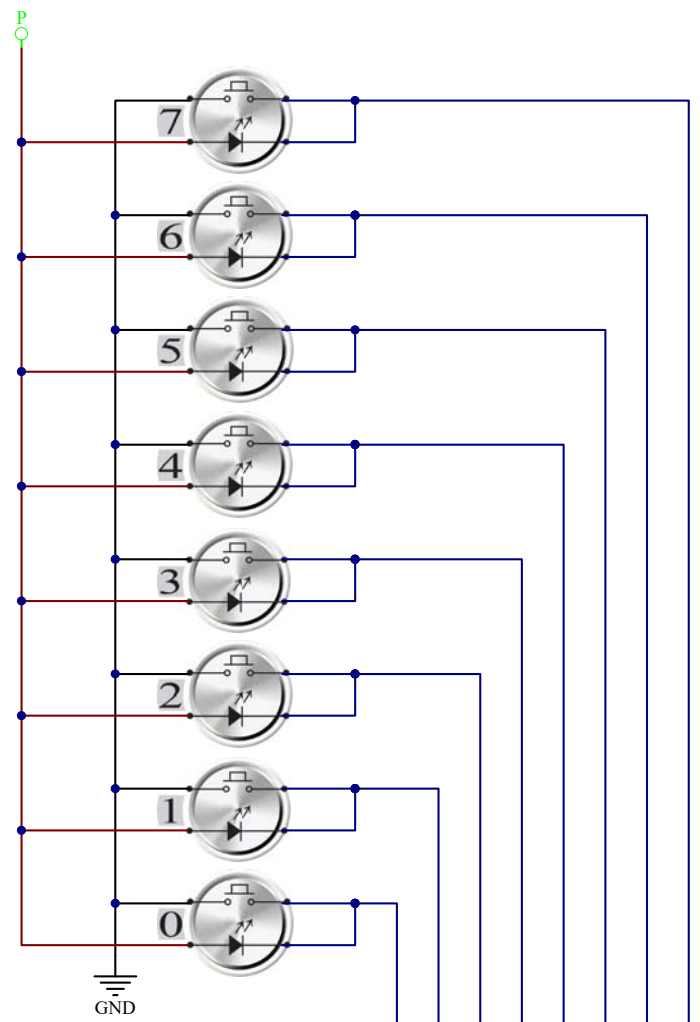

**LAND CALLS DOWN**

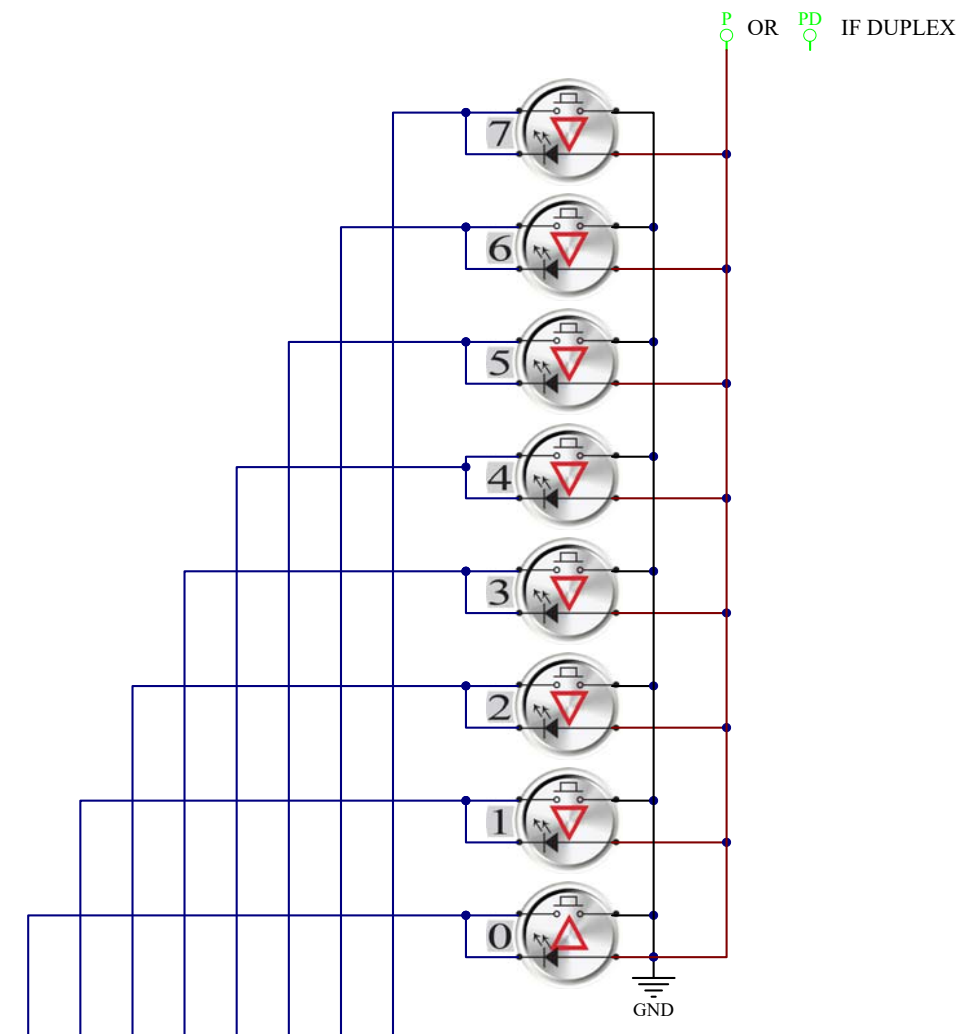

**MICROZED V3.5 BOARD**

S.&A.S. Ltd.  
 Jieh Chouf  
 Lebanon  
 support@sascontrollers.com

**MICROZED V3.5 WIRING DIAG: CALLS W/O EXTENSION  
 DOWN COLLECTIVE - 8 STOPS**

Size B	FCSM No. -	DWG No. A350AC2SV1W8_CALLS-Dn8.Sch	Rev 1
Scale -	Sheet 8 of 14		



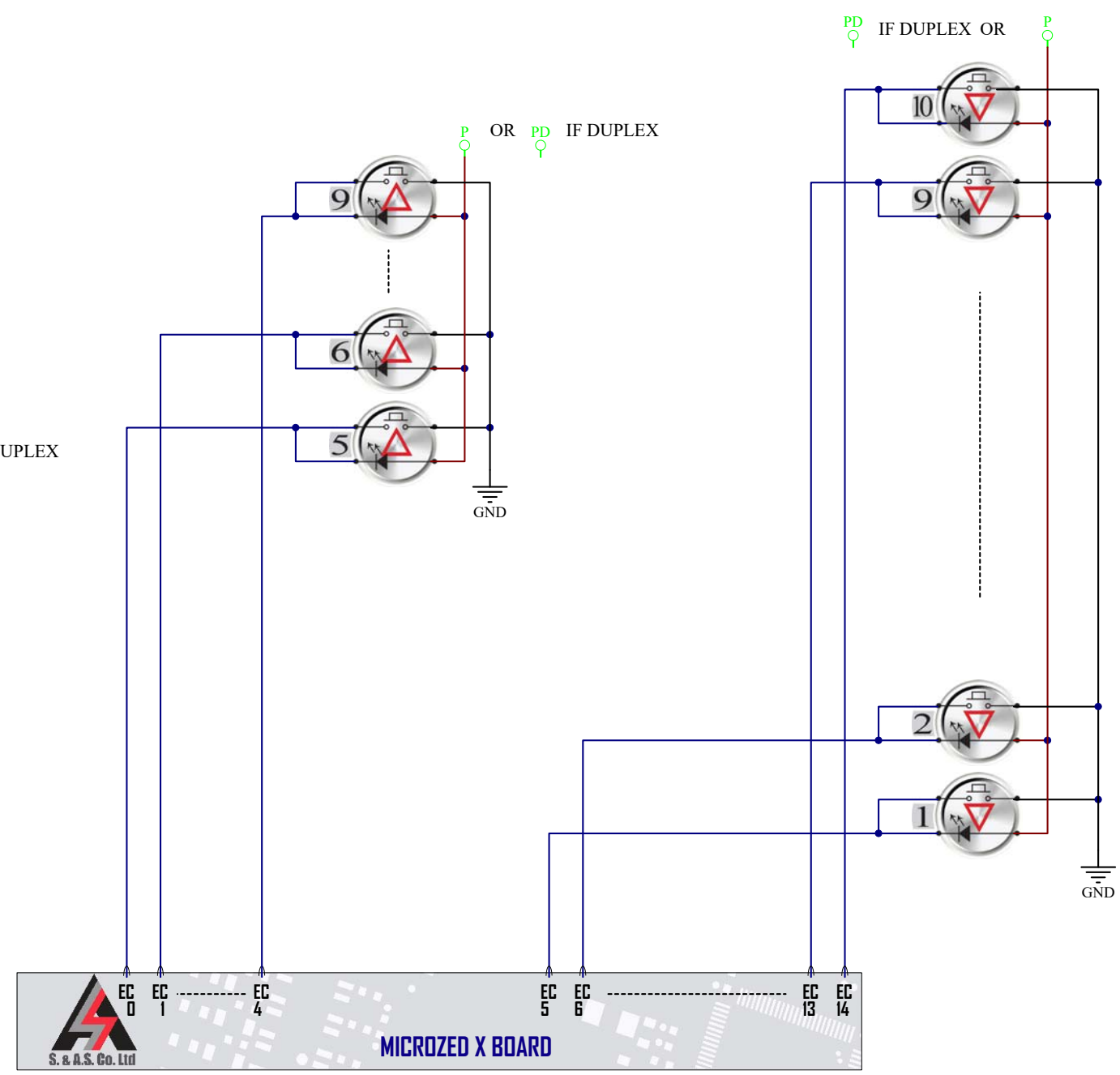
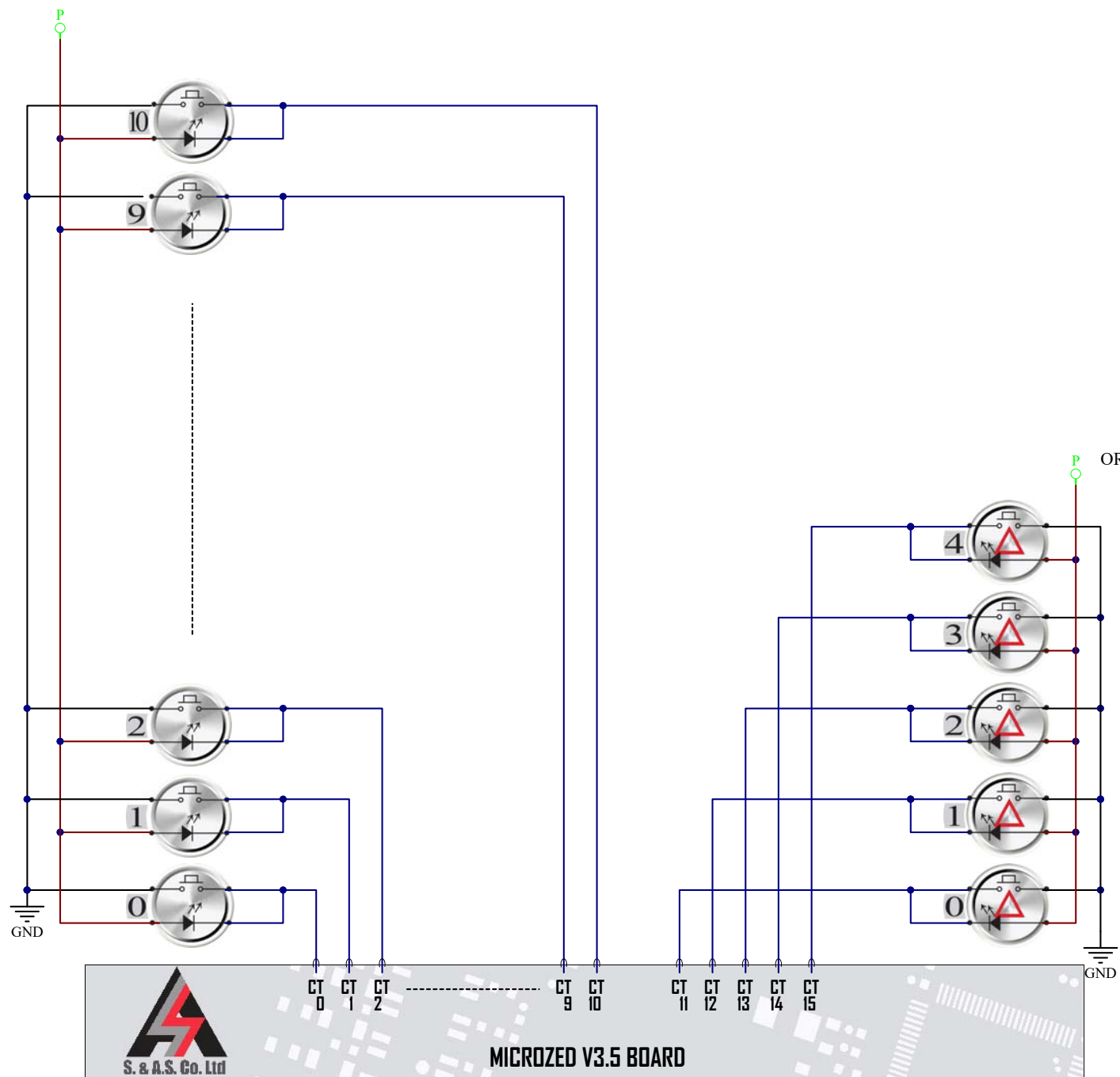

S.&A.S. Ltd.  
 Jieh Chouf  
 Lebanon  
 support@sascontrollers.com

MICROZED V3.5 WIRING DIAG: **CALLS WITH 1 EXTENSION FULL COLLECTIVE - 11 STOPS**

Size B	FCSM No. -	DWG No. A350AC2SV1W9_CALLS-Full11_With1Ext	Rev 1
Scale -	Sheet 9 of 10		

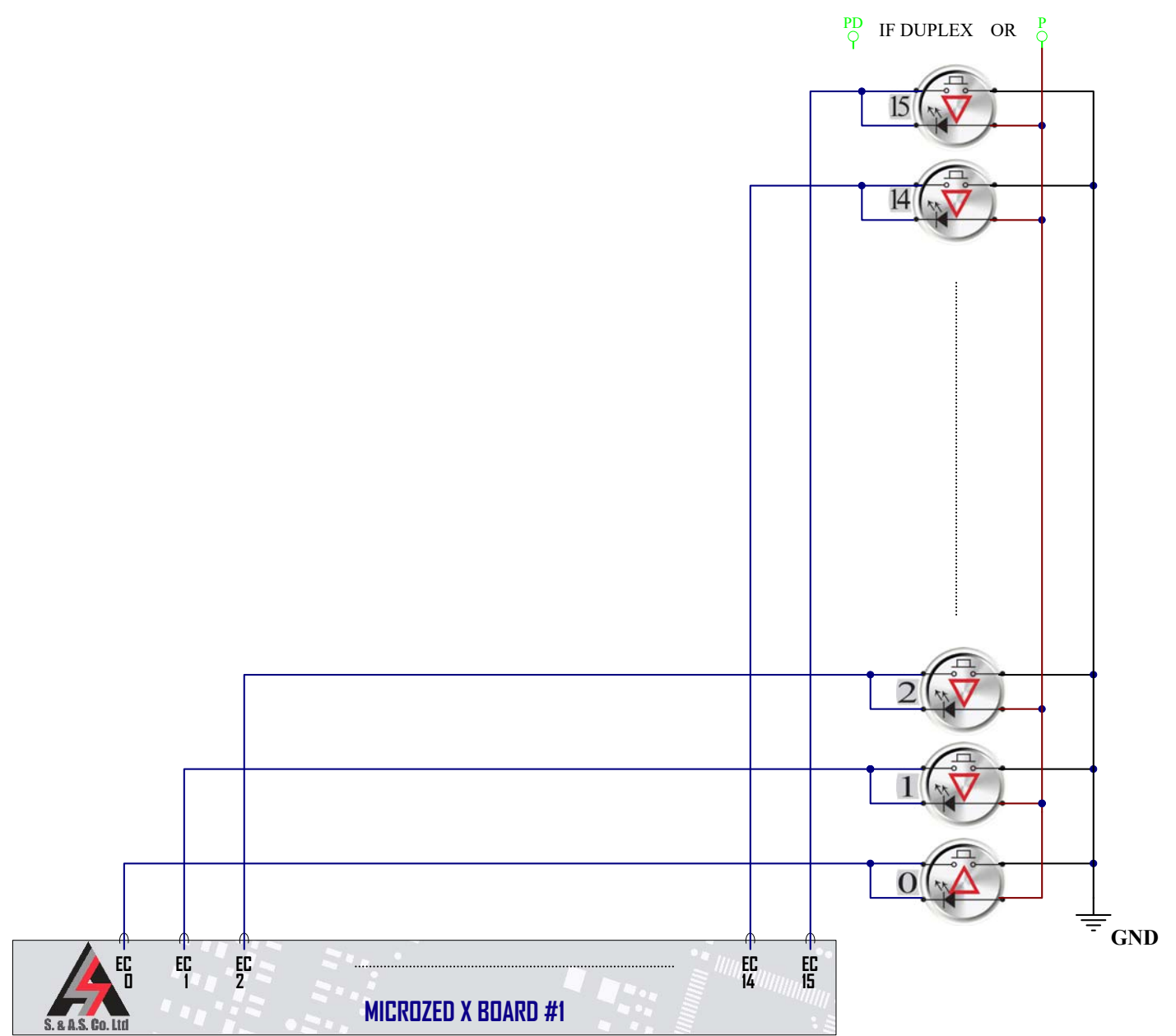
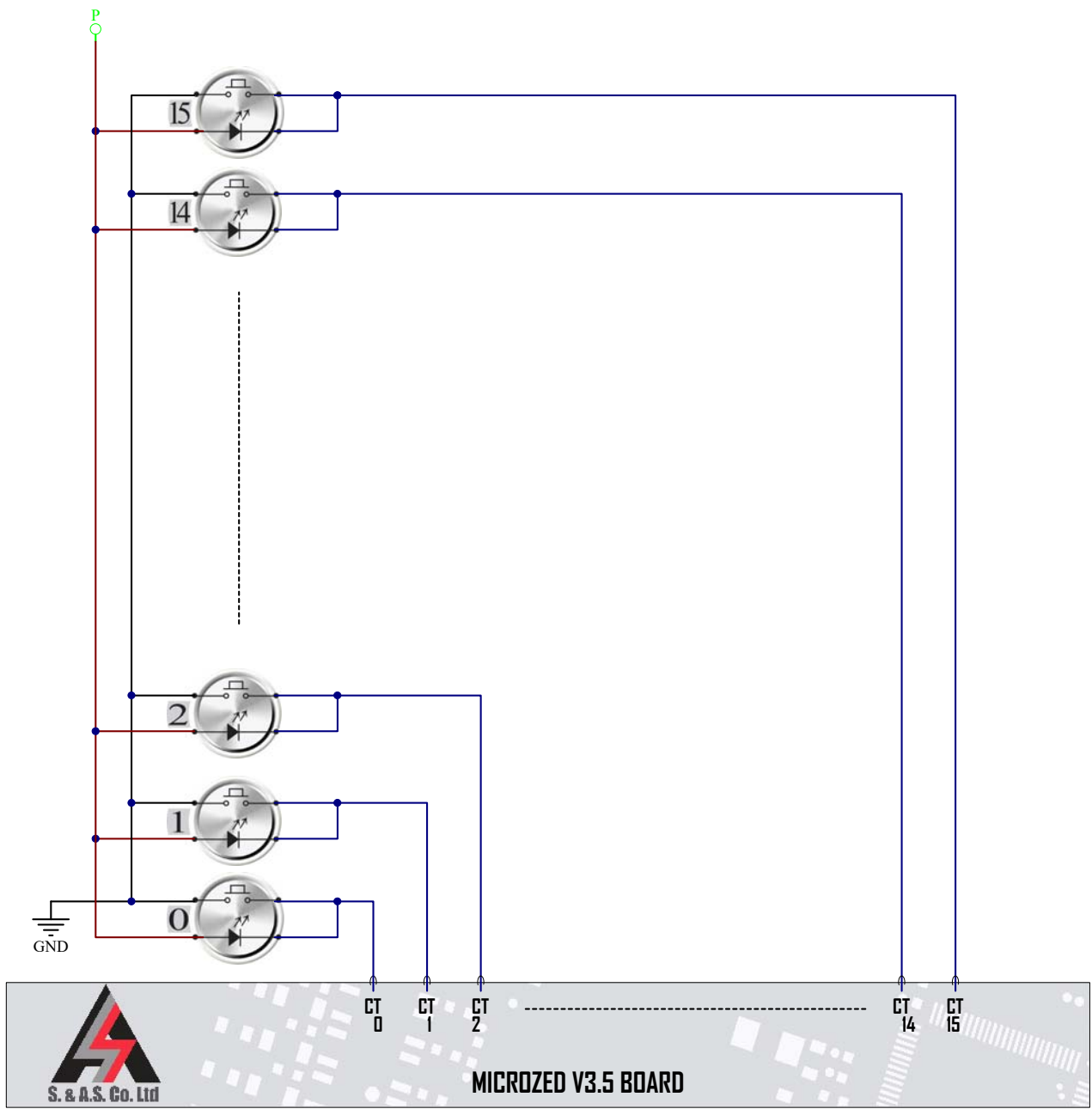

<b>S.&amp;A.S. Ltd.</b> <b>Jieh Chouf</b> <b>Lebanon</b> <b>support@sascontrollers.com</b>			
<b>MICROZED V3.5 WIRING DIAG: CALLS WITH 1 EXTENSION DOWN COLLECTIVE - 16 STOPS</b>			
Size B	FCSM No. -	DWG No. A350AC2SV1W10_CALLS-Dn16_With1Ext	Rev 1
Scale -	Sheet		10 of 14

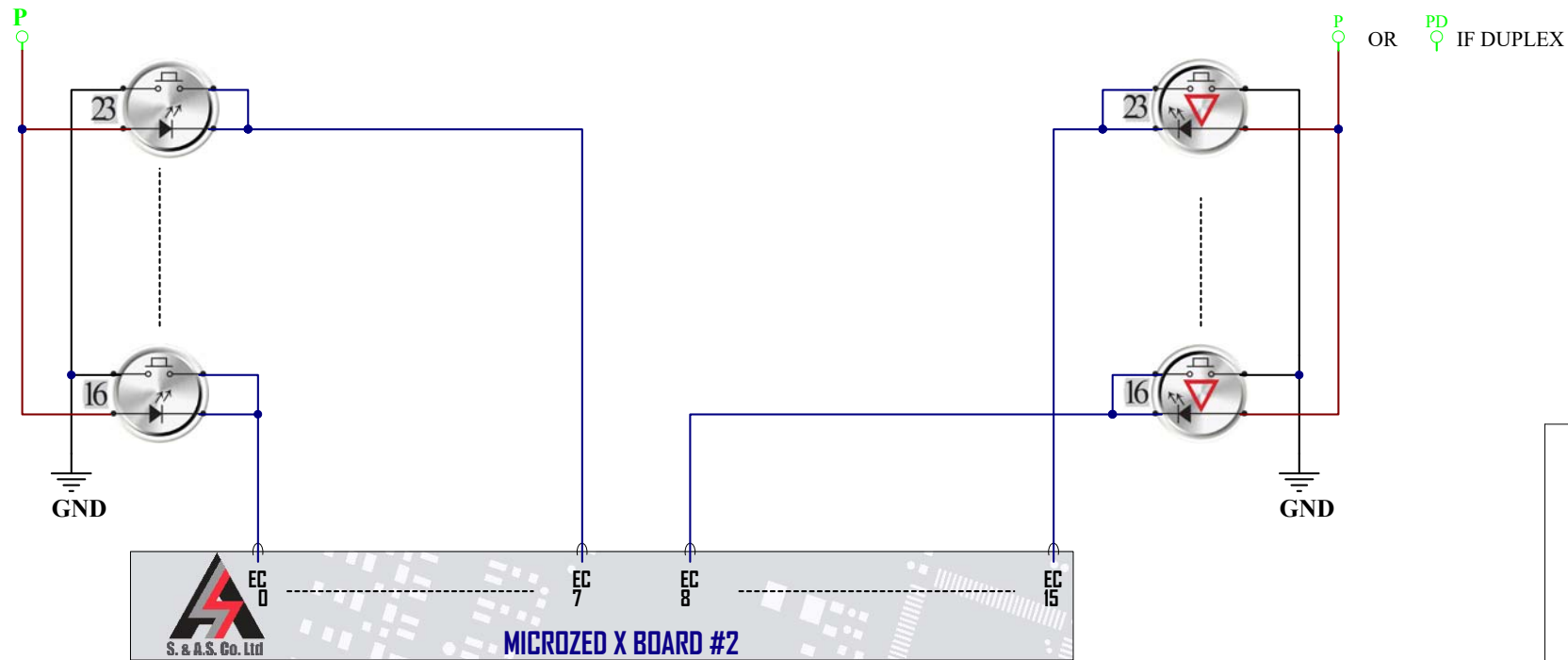
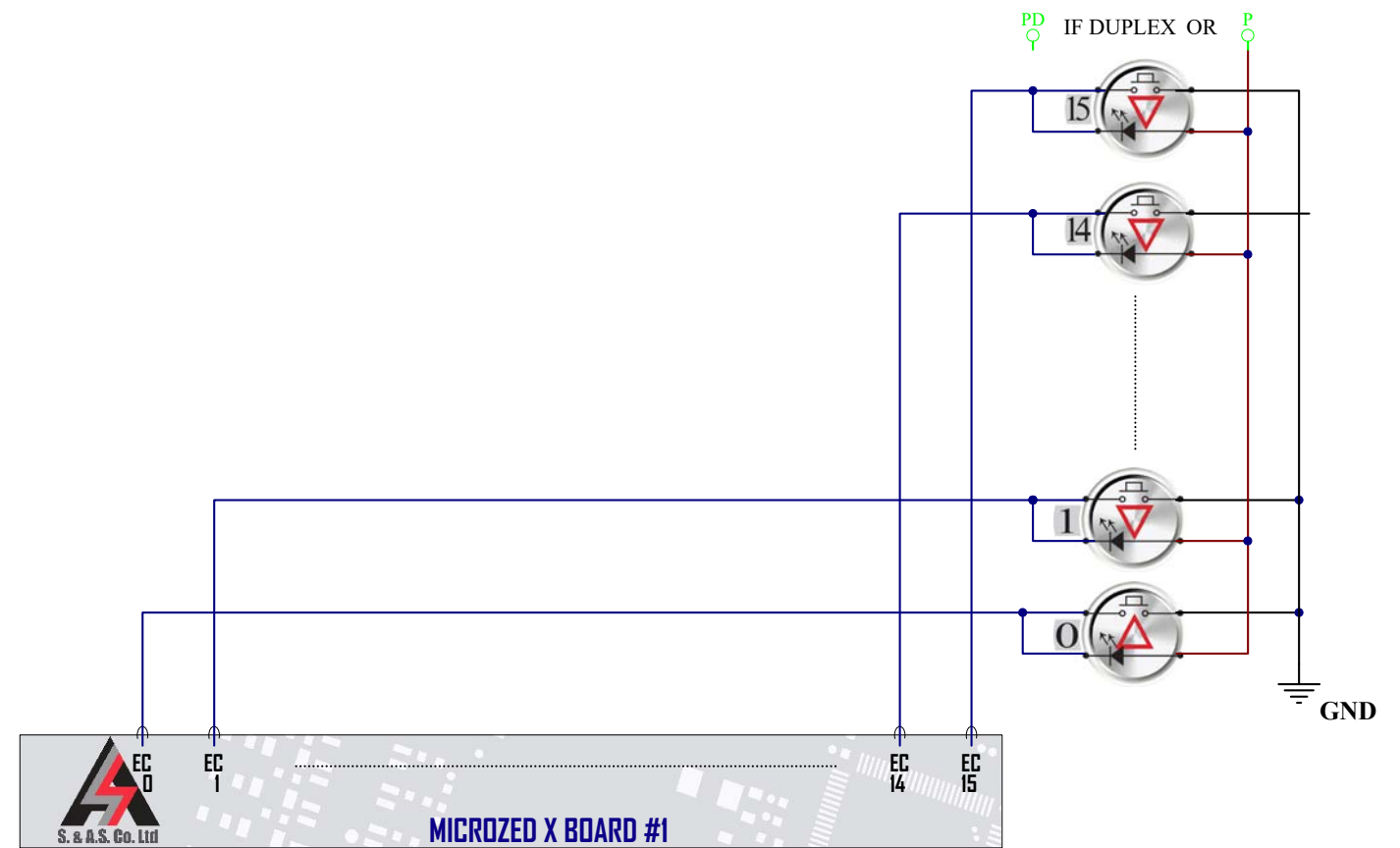
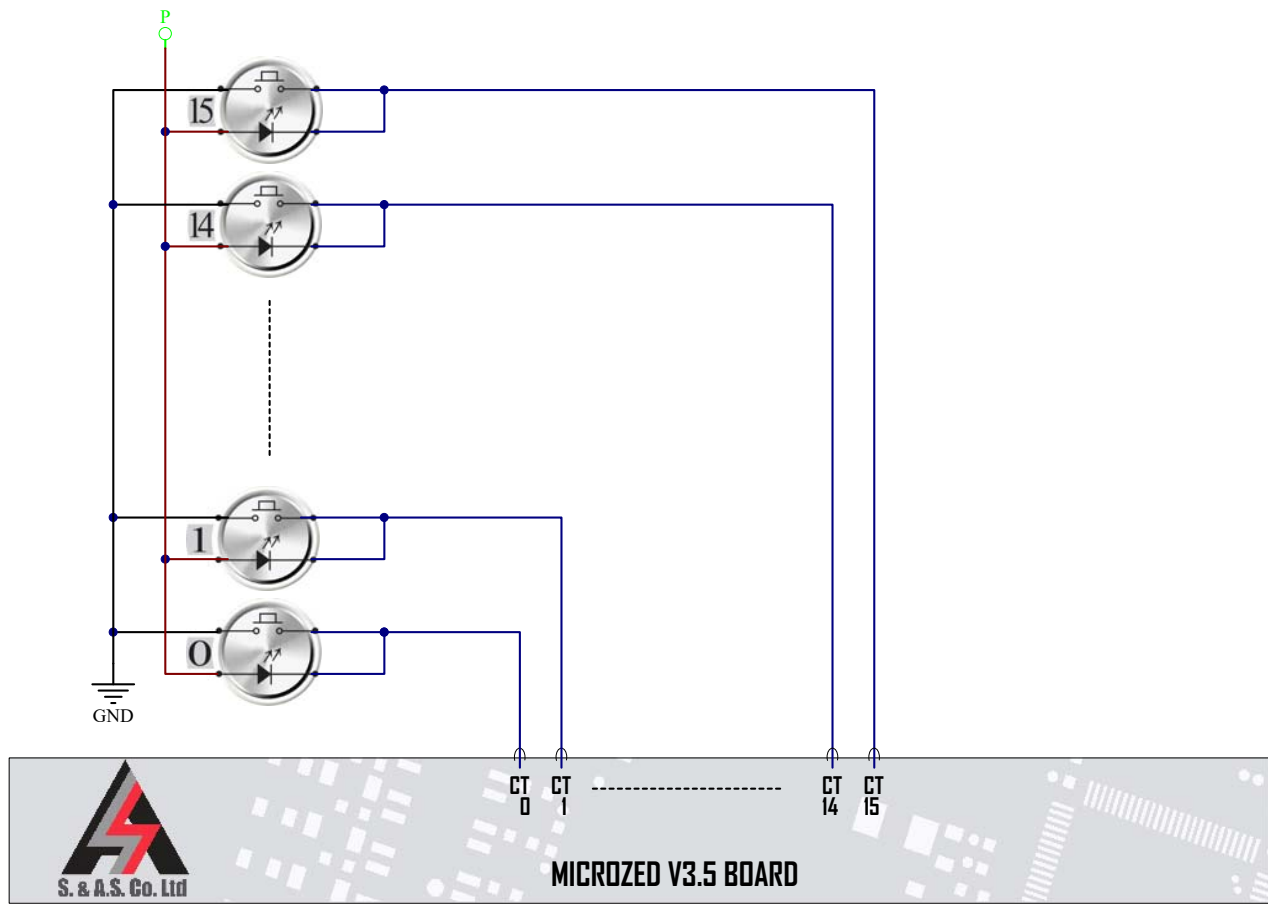

S.&A.S. Ltd.  
Jieh Chouf  
Lebanon  
support@sascontrollers.com  
**MICROZED V3.5 WIRING DIAG: CALLS WITH 2 EXTENSIONS  
DOWN COLLECTIVE- 16 STOPS**

Size B	FCSM No. -	DWG No. A350AC2SV1W11_CALLS-Dn16_With2Ext.Sch	Rev 1
Scale -	Sheet 11 of 14		

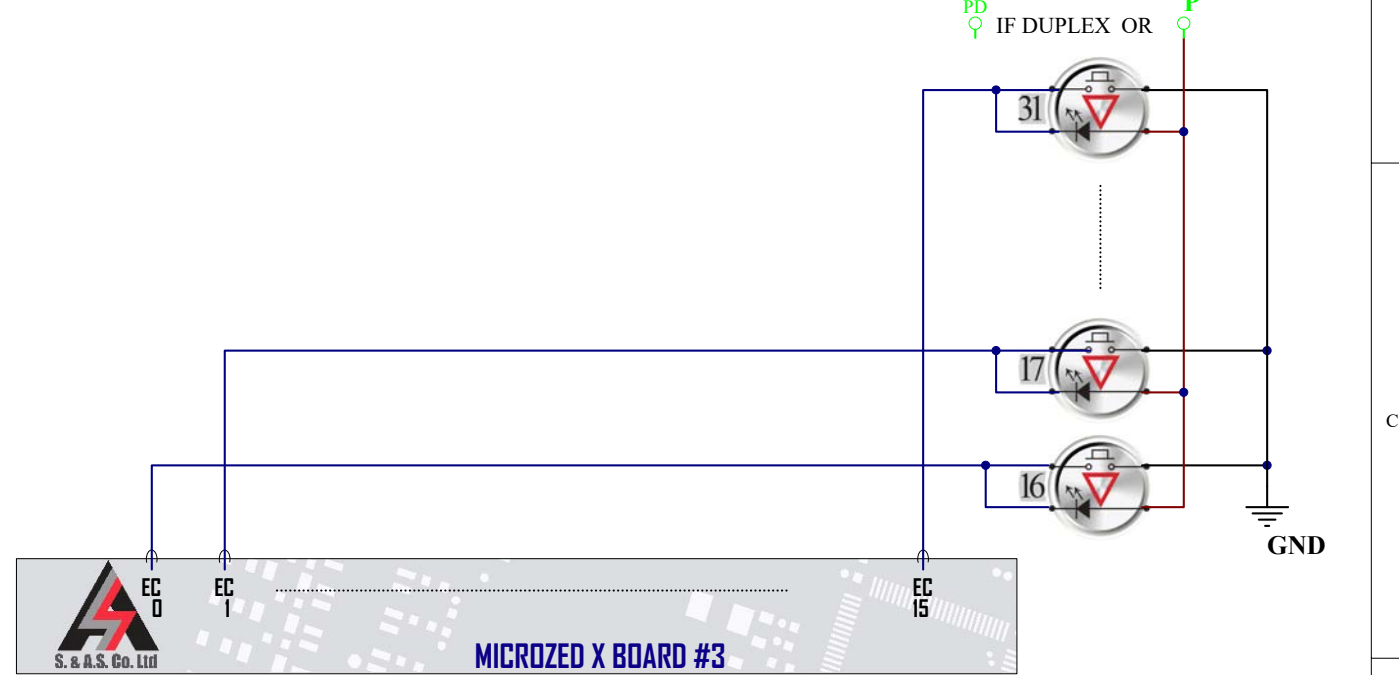
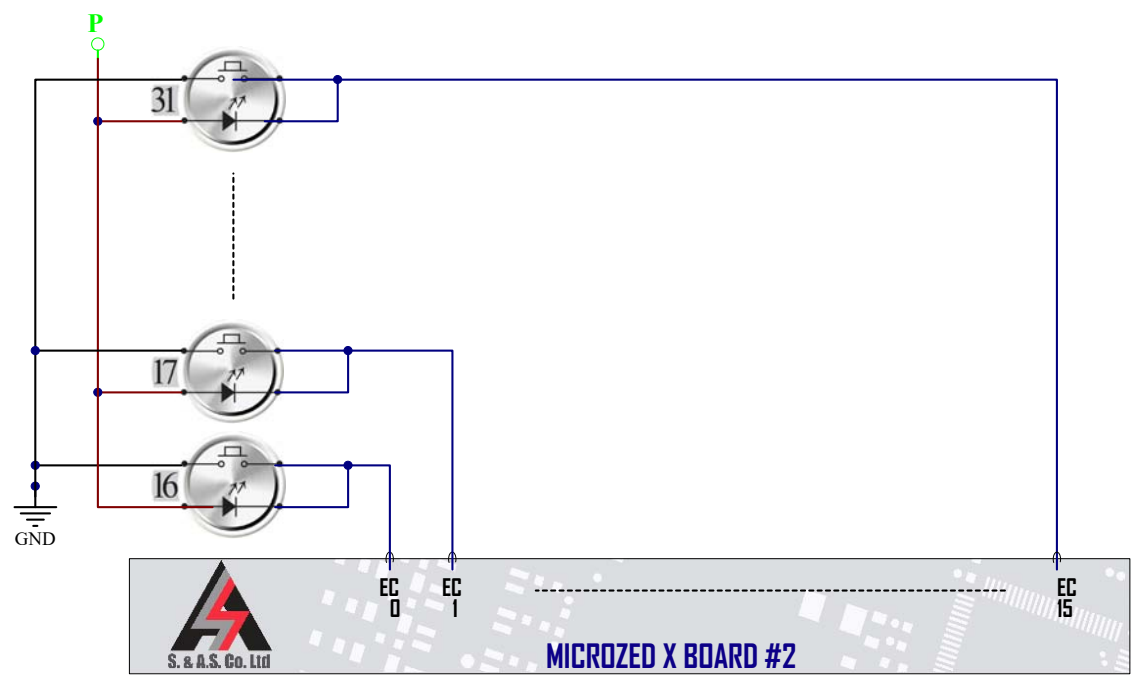
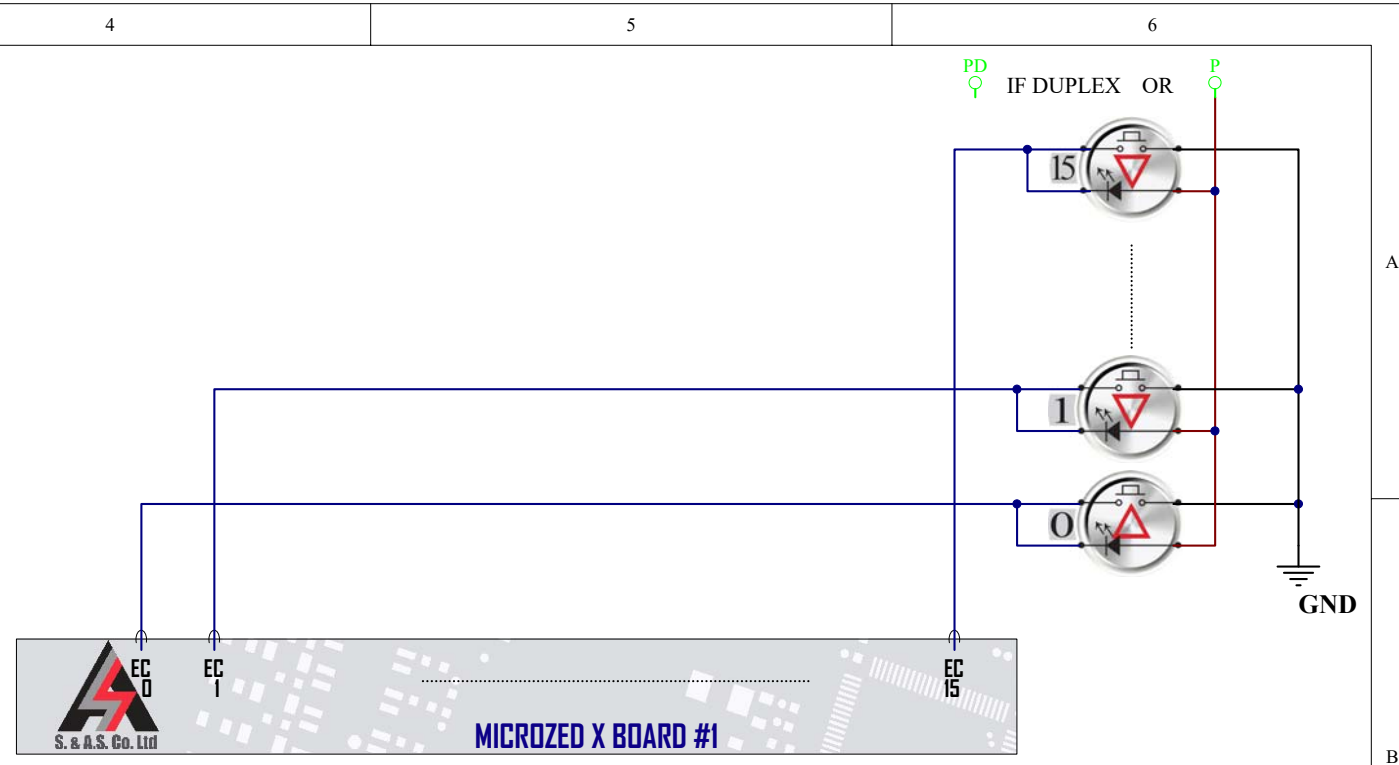
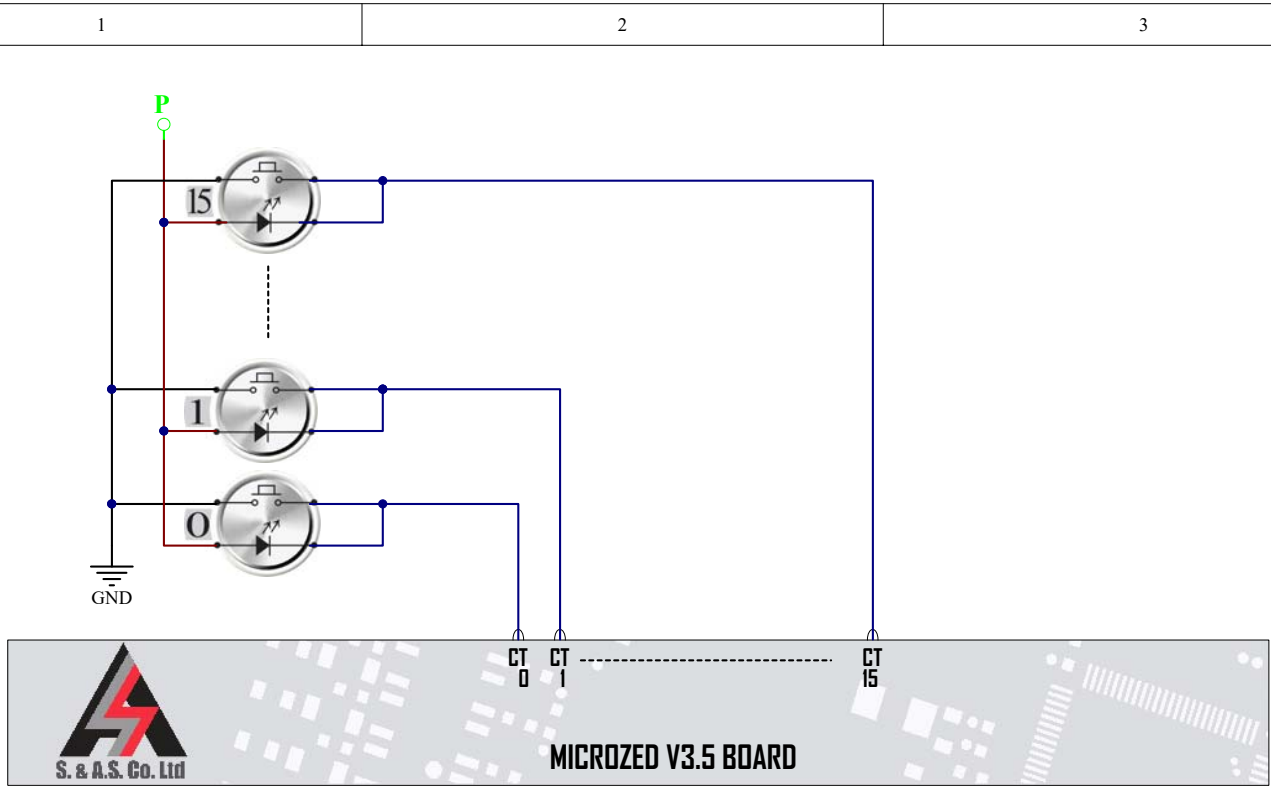

S.&A.S. Ltd.  
 Jieh Chouf  
 Lebanon  
 support@sascontrollers.com

**MICROZED V3.5 WIRING DIAG: CALLS WITH 3 EXTENSIONS  
 DOWN COLLECTIVE- 16 STOPS**

Size B	FCSM No. -	DWG No. A350AC2SV1W12_CALLS-Dn16_With3Ext	Rev 1
Scale -	Sheet 12 of 14		



MICROZED V3.5 BOARD

INDICATR="ENHANCED" or  
"7SEGMENT"

COLLECTV="DOWN"

S.&A.S. Ltd.  
Jieh Chouf  
Lebanon  
support@sascontrollers.com

MICROZED V3.5 WIRING DIAG: CALLS - COLLECTIVE MULT DOWN - 16  
STOPS

Size B	FCSM No. -	DWG No. A350AC2SV1W13_CALLS-COLLECTIVE_MULT_Dn16.Sch	Rev 1
Scale -	Sheet 13 of 14		

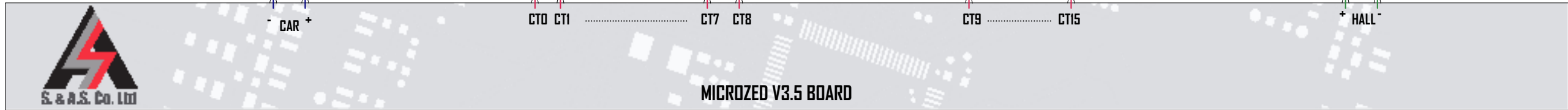

<b>S.&amp;A.S. Ltd.</b> Jieh Chouf Lebanon <a href="mailto:support@sascontrollers.com">support@sascontrollers.com</a>			
<b>MICROZED V3.5 WIRING DIAG: CALLS - COLLECTIVE MULT FULL-9 stops</b>			
Size B	FCSM No. -	DWG No. A350AC2SV1W14_CALLS-COLLECTIVE_MULT_Full16.Sch	Rev 1
Scale -	Sheet		14 of 14