

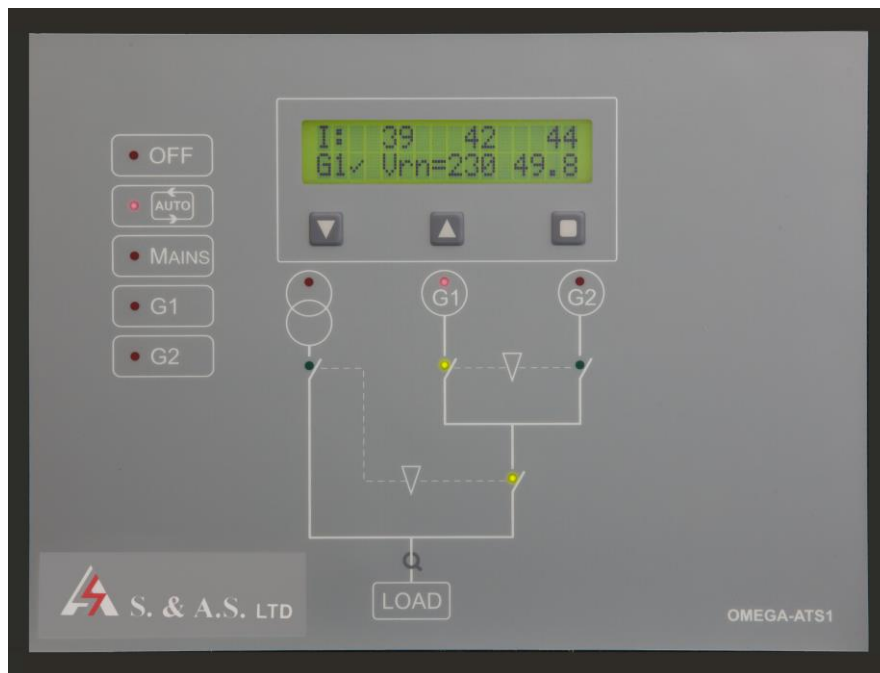

**S. & A.S. LTD**

# **AUTOMATIC TRANSFER SWITCH CONTROLLER FOR 2 GENSETS OF DIFFERENT RATING – OMEGA-ATSO**



## **USER'S MANUAL**

FOR HW VERSION 1.0  
FOR S/W VERSION 3.00  
1610

**Beirut Office:**  
Boutros Building 1<sup>st</sup> Basement  
Cheikh-el-Ghabi Street  
Ghabi Beirut 2068 7808  
Lebanon  
Tel: +961 1 216 994  
Fax: +961 1 339 600

**Headquarters & Factory:**  
S. & A. S. Building  
Seaside Road  
Jieh Chouf  
Lebanon  
Tel: +961 7 996 333  
Fax: +961 7 996 116

**Website:**  
[www.sascontrollers.com](http://www.sascontrollers.com)

**Technical Support & Email:**  
Tel: +961 71 996 333  
[support@sascontrollers.com](mailto:support@sascontrollers.com)

1	INTRODUCTION .....	3
2	FEATURES .....	3
3	OPERATION .....	3
4	FRONT PANEL DESCRIPTION.....	4
4.1	MEASURED AND DISPLAYED PARAMETERS.....	4
4.2	FRONT PANEL LEDS .....	4
4.3	DETECTED AND SIGNED FAULTS.....	4
5	REAR PANEL DESCRIPTION .....	5
5.1	TERMINAL DESCRIPTION .....	5
5.2	LEDS DESCRIPTION .....	6
6	MENU DESCRIPTION.....	6
6.1	PARAMETER DESCRIPTION .....	7
7	TECHNICAL SPECIFICATION .....	7
8	CASE DIMENSIONS .....	7
9	TYPICAL WIRING DIAGRAM .....	7

## 1 INTRODUCTION

This module controls up to three power sources: mains and two generators of different ratings (**MGG**). It can also be configured to control two generators (**GG**). It features isolated measurement of the voltages and frequency on all three sources as well as the current on the load side. It has four operating modes selectable by the user: OFF, AUTO, MAINS, G1 or G2. Front panel leds signal the installation status in addition to the faults. The user interface consists of a 16-character alphanumeric lcd displays. Three front panel push buttons are provided to select the operating mode and to access a menu of parameters. The menu gives access to all timers, set points and other parameters relevant to the control and protection of the installation.

## 2 FEATURES

- Microcontroller based design
- Measurement and display of the voltages and frequency on the three sources
- Measurement and display of the current on the load side
- All three supplies are monitored for over/under voltage, phase presence and sequence
- All three supplies are monitored for over/under frequency
- Load side is monitored for over current when it is not supplied by the Mains
- Display switches automatically to show the measurements of the source feeding the load
- Automatic switching between the two gensets based on the load
- Weekly exerciser function
- Ability to control contactor and motorized circuit breakers
- Easy to fit DIN standard 196x144 panel mount housing
- Connection is via locking plug and socket connectors
- Front panel leds for status and alarm indication
- Menu to provide access to all timers, set points and other parameters
- Over / Under frequency alarm and shut down
- Over / Under voltage alarm and shut down
- Over current alarm and shut down

## 3 OPERATION

Four operating modes are provided. To switch from one mode to another, scroll to the page that says "Operating Mode" using the up or down push buttons. Use the select push button to change the mode. Following is description of the operating modes:

- **OFF**: In this mode the module cuts power completely from the load.
- **AUTO**: The module monitors the Mains supply. When the Mains fails or its contactor fails to engage, it starts genset G1 (the smaller genset) or G2 (the bigger genset) depending on the load measured prior to mains failure after a response delay<sup>1</sup>. Load is engaged after the elapse of the warm-up delay<sup>2</sup>. When the Mains is re-established, the power is switched back with a dead time<sup>3</sup> after a restoration delay<sup>4</sup> and the genset is shut down after the elapse of the cooling time<sup>5</sup>. In case the requested genset fails to start or its contactor fails to engage or it shuts down due to any fault, the other genset will automatically start and supply the load. Following a mains failure, G2 is requested if the load prior to mains failure was above the maximum load of G1<sup>6</sup>, otherwise, G1 is requested. The value of the load supplied by the Mains is retained for 5 minutes only. So if 5 minutes have elapsed from the mains failure, G2 is started always. This could occur when switching to AUTO mode from Mains or OFF modes. If G1 is feeding the load and the current goes above the G1 maximum load for a MaxLd delay<sup>7</sup>, G2 is requested. If G2 is feeding the load and the current goes below the G2 minimum load<sup>8</sup> for a MinLd delay<sup>9</sup>, G1 is requested. In GG installation, the generators get requested only if the Remote Control input is activated (low). Please refer to section 4 for display and led function description.
- **Mains**: The module monitors the Mains supply. The load is fed exclusively from this supply if it is within the acceptable limits. No gensets will be started if the Mains fails.
- **G1**: In this mode and regardless of the status of the Mains supply, the module starts G1 and engages the load after warm-up delay.
- **G2**: In this mode and regardless of the status of the Mains supply, the module starts G2 and engages the load after warm-up delay.

<sup>1</sup> Response delay is presettable in the menu. Refer to section 6.

<sup>2</sup> Warm-up delay is presettable in the menu. Refer to section 6.

<sup>3</sup> Xfr deadtim is presettable in the menu. This dead time is also applicable when switching between the two gensets. Refer to section 6.

<sup>4</sup> Restoration Delay is presettable in the menu. Refer to section 6.

<sup>5</sup> Cooling time is presettable in the menu. Refer to section 6.

<sup>6</sup> G1Maximum Load is presettable in the menu. Refer to section 6.

<sup>7</sup> G1 MaxLd Delay is presettable in the menu. Refer to section 6.

<sup>8</sup> G2 Minimum Load is presettable in the menu. Refer to section 6.

<sup>9</sup> G2 MinLd Delay is presettable in the menu. Refer to section 6.

In case contactors are used for the transfer switch, each contactor is controlled by one dry contact. The other dry contact is used as an alarm output (CxD.NO). If motorized circuit breakers are used, each motorized circuit breaker is controlled by two relays: first has one normally open dry contact (CxENG) and is used to engage the motorized circuit breaker by giving a pulse of 1 second, the second is controlled by a contact that has a common (CxC), normally open (CxD.NO) and normally closed (CxD.NC) contacts to disengage the motorized circuit breaker by giving a pulse of 1 second as well.

## 4 FRONT PANEL DESCRIPTION

### 4.1 MEASURED AND DISPLAYED PARAMETERS

- The currents on the three phases are measured and displayed simultaneously.
- The line-neutral and line-line voltages are all measured. The voltage displayed is either fixed or will automatically scroll between all six voltages (rn, sn, tn, rs, st, tr) by pushing the Select push button.
- The frequency is measured and permanently displayed.
- Display switches automatically to show the measurements of the source supplying the load. The source (M, G1 or G2) is indicated on the lower left corner of the display. A “√” next to the source name indicates that source is normal and is supplying the load. An “!” indicates that source or its contactor has an anomaly that caused a shutdown, pressing the Select button (button on the right) will reset the anomaly of this source. The following anomalies are shown only before engaging the load. “f” next to the source name indicates a frequency anomaly. “v” indicates a voltage anomaly. “r” indicates wrong phase sequence.

### 4.2 FRONT PANEL LEDS

- Four leds are used to indicate the operating mode.
- Mains supply has one red led. Led ON indicates that the Mains supply is within the acceptable limits, the phases are all present and in the right sequence. Led OFF indicates a fault in the mains supply.
- Mains contactor (or motorized circuit breaker) has one green led. Led OFF means that the contactor is not engaged. Led blinking means that the contactors has been energized but has not engaged yet. Led ON indicates that the contactor (or motorized circuit breaker) is engaged.
- Each genset has one red led. Led OFF means that the genset is not requested to start. Led blinking means that the genset has been requested to start or genset has failed to start or has an anomaly in its supply. Led ON indicates that genset is running and ready to supply the load.
- Each genset has one green led. Led OFF means that the contactor is not engaged. Led blinking means that the contactors has been energized but has not engaged yet. Led ON indicates that the contactor (or motorized circuit breaker) is engaged.
- The contactor (or motorized circuit breaker) on the load supply from the gensets side has one green led. This contact is not directly controlled by the Omega-ATS. Led OFF means that the contactor is not engaged. Led blinking means that the contactor has been energized but has not engaged yet. Led ON indicates that the contactor (or motorized circuit breaker) is engaged.

### 4.3 DETECTED AND SIGNALLED FAULTS

Fault	Comments
Fail to start	Corresponding red led blinking
Cont. jammed	Corresponding green led blinking
Reverse	Indicates shut down due to wrong sequence of phases
Over voltage	Indicates shut down due to an over voltage
Under voltage	Indicates shut down due to an over voltage
Phase failure	Indicates shut down due to a phase failure
Over freq.	Indicates shut down due over frequency
Under freq.	Indicates shut down due under frequency
Over Load	Indicates shut down due to an overload

**Fail to start** fault occurs in the following scenarios:

- The generator is requested but it does not turn on.
- The generator is requested, it turns on but the start feedback does not turn on.
- The generator is requested, it turns on and the start feedback turns on, but there is over/under voltage or frequency.
- The generator is requested, it turns on and is counting the warm-up delay or the transfer dead time delay and the start fail delay expires.

**Cont. Jammed** fault occurs in the following scenarios:

- The generator is on and requesting the load to be engaged, but the start fail delay expires before the load is engaged.
- The generator is on and feeding the load, but the load disengages.

## 5 REAR PANEL DESCRIPTION

### 5.1 TERMINAL DESCRIPTION

CONNECTOR						
P1			P2			
TERMINAL	1	-VBAT SUP	-ve battery supply	7	CG F/B	Feedback from G contactor (-ve)
	2	+VBAT SUP	+ve battery supply	8	CM F/B	<b>MG &amp; MGG:</b> F/B M contactor (-ve) <b>GG:</b> Remote control (-ve)
	3	G1 OK	Signal from Autostart of G1 (-ve)	9	ST.G1 C	Output to start G1 - common
	4	G2 OK	Signal from Autostart of G2 (-ve)	10	ST.G1 NO	Output to start G1 - normally opened
	5	CG1 F/B	Feedback from G1 contactor (-ve)	11	ST.G2 C	Output to start G2 - common
	6	CG2 F/B	Feedback from G2 contactor (-ve)	12	ST.G2 NO	Output to start G2 - normally opened

CONNECTOR						
P3			P4			
TERMINAL	13	CG1 C	Contactors (or motorized CB) G1 – common	19	CG2 D.NC	Motorized CB G2 disengage – normally closed
	14	CG1 ENG	Contactors (or motorized CB) G1 engage – normally opened	20	CG2 <sup>1</sup> D.NO	Motorized CB G2 disengage – normally opened
	15	CG1 D.NC	Motorized CB G1 disengage – normally closed	21	CM C	Contactors (or motorized CB) Mains – common
	16	CG1 <sup>1</sup> D.NO	Motorized CB G1 disengage – normally opened	22	CM ENG	Contactors (or motorized CB) Mains engage – normally opened
	17	CG2 C	Contactors (or motorized CB) G2 – common	23	CM D.NC	Motorized CB Mains disengage – normally closed
	18	CG2 ENG	Contactors (or motorized CB) G2 engage – normally opened	24	CM <sup>2</sup> D.NO	Motorized CB Mains disengage – normally opened

CONNECTOR						
P5			P6			
TERMINAL	25	CT T P2	Current transformer on line T – p2	31	N MAIN	Neutral - Mains supply
	26	CT T P1	Current transformer on line T – p1	32	LINE TM	Line T - Mains supply
	27	CT S P2	Current transformer on line S – p2	33	NOT USED	Not used
	28	CT S P1	Current transformer on line S – p1	34	LINE SM	Line S - Mains supply
	29	CT R P2	Current transformer on line R – p2	35	NOT USED	Not used
	30	CT R P1	Current transformer on line R – p1	36	LINE RM	Line R - Mains supply

CONNECTOR						
P7			P8			
TERMINAL	37	N G1	Neutral - G1 supply	43	N G2	Neutral – G2 supply
	38	LINE TG1	Line T - G1 supply	44	LINE TG2	Line T – G2 supply
	39	NOT USED	Not used	45	NOT USED	Not used
	40	LINE SG1	Line S - G1 supply	46	LINE SG2	Line S – G2 supply
	41	NOT USED	Not used	47	NOT USED	Not used
	42	LINE RG1	Line R – G1 supply	48	LINE RG2	Line R – G2 supply

<sup>1</sup> Used as an alarm output if fault exists on G1 or G2 in case contactors are used for the transfer switch

<sup>2</sup> Used as an alarm output if utility is absent in case contactors are used for the transfer switch

## 5.2 LEDS DESCRIPTION

The rear panel leds signal the status of the digital inputs:

Led No.	Color	Correspondent input
1	Red	G1 OK signal (from autostart)
2	Red	G2 OK signal (from autostart)
3	Red	Contactora G1 feedback
4	Red	Contactora G2 feedback
5	Red	Contactora G feedback
6	Red	Contactora M feedback

## 6 MENU DESCRIPTION

Follow the steps described below to access the menu:

1. Use the up or down push buttons to scroll to the "Enter the Menu?" page. Press the ENTER push button once. You will be prompted to enter a four-digit code. The default password is 0000.
2. Use the UP and DOWN push buttons to scroll to the desired number.
3. Press the ENTER push button. "\*" replaces the first digit.
4. Repeat steps 2. and 3. until all four digits are entered.

If the entered password is valid, the user will have access to the menu below. If no push buttons are pressed for 5 minutes while in the menu, the system will automatically exit the menu.

Parameter Displayed	Range	Factory setting
Response	0 to 255 sec	5 sec
Flt bypass	0 to 255 sec	15 sec
Warm-up	0 to (StartFail-Xfr deadtim -10) sec	10 sec
Mains Rest.	0 to 255 sec	10 sec
Cooling	0 to 255 sec	30 sec
U-OverFreq. Hz	Dis, 10 to 70Hz	55Hz
U-OverFrq dly	0 to 255 sec	2 sec
U-UnderFreq. Hz	Dis, 10 to 70Hz	45Hz
U-UnderFrq dly	0 to 255 sec	5 sec
U-OverVolt. V	Dis, 1 to 255V	240V
U-OverVlt.dly	0 to 255 sec	3 sec
U-UnderVolt. V	Dis, 1 to 255V	200V
U-UnverVlt.dly	0 to 255 sec	5 sec
G-OverFreq. Hz	Dis, 10 to 70Hz	55Hz
G-OverFrq dly	0 to 255 sec	2 sec
G-UnderFreq. Hz	Dis, 10 to 70Hz	45Hz
G-UnderFrq dly	0 to 255 sec	5 sec
G-OverVolt. V	Dis, 1 to 255V	240V
G-OverVlt.dly	0 to 255 sec	3 sec
G-UnderVolt. V	Dis, 1 to 255V	200V
G-UnverVlt.dly	0 to 255 sec	5 sec
CT ratio /5	0/5 to 9999/5	100/5
G1 Overload %	0 to 255%	90%
G1 Overld dly	0 to 255 sec	10 sec
G2 Overload %	0 to 255%	90%
G2 Overld dly	0 to 255 sec	10 sec
G1 Max Load %	0 to 255%	50%
G1 Maxld dly	0 to 255 sec	10 sec
G2 Min Load %	0 to 255%	30%
G2 Minld dly	0 to 255 sec	10 sec
Start Fail	(Warm-up+Xfr deadtim +10) to 255 sec	30 sec
Xfr deadtim	0 to (StartFail - Warm-up - 10) sec	0 sec
Hold Start	Dis/Ena	Ena
Time switch	Dis/Ena	Dis
07:30am 05:00pm (Time switch enabled)		08:00am 05:00pm
W.Exersice	Dis/Ena	Dis
ATS Type	Cont/MCB (motorized CB)	Cont
Req Priority	G1/G2/Ld (G1, G2 or according to load)	G1 for MGG G2 for GG
LCD Contrast	40 to 255	80
Co.	8 letters	S.& A.S.Ltd.
Time	##:##am or pm	-

Parameter Displayed	Range	Factory setting
Date	DD/MM/YY	-
Day	Sun to Sat	-
G1 hours	0 to 999999 hours	0 hours
G2 hours	0 to 999999 hours	0 hours
Exit Menu	N/A	N/A

### 6.1 PARAMETER DESCRIPTION

The **U-** before any parameter indicates that the parameter is related to the Mains, while a **G-** before the parameter indicates that the parameter is related to the generators.

The over/under freq./voltage could be disabled by setting the corresponding parameter in the menu to Dis.

When transferring load from one generator to another, the transfer deadtime and the warmup delay are counted. To avoid getting a fault on the generator, the sum of these delays should not exceed the startfail delay of the generator. Thus, the startfail delay should never fall below (transfer deadtime + warmup +10sec).

When **Hold start** feature is enabled, the start signal is held on the generator after a fault occurs. Thus, when the fault no longer exists, the generator starts without user intervention. When it is disabled, the start signal is removed and a manual reset of the fault is required to resume use of the specific generator.

The **W. Exercise** parameter enables/disables the weekly exerciser. When enabled, any generator that did not operate between Sunday and Friday would be started on Saturday at 8:00 am for half an hour. If both were not used during the whole week, they will be started on Saturday at 8:00AM in sequence and each for half an hour.

The **ATS Type** indicates whether contactors (Cont) are used or motorized circuit breakers (MCB).

### 7 TECHNICAL SPECIFICATION

Supply voltage range	5 to 33Vdc
Maximum supply current	550mA on 12Vdc – 275mA on 24Vdc
Standby supply current <sup>1</sup>	400mA on 12Vdc – 30mA on 24Vdc
Digital inputs activation logic	Low (ground)
Output relays rating	10A 250V ac1
AC inputs range (L-N)	0 to 280Vac
CT inputs range	0 to 5Amps
Operating temperature	-30 to 70°C
User access	Three touch buttons
Data sampling rate	0.4 samples/sec
Dimensions	192x144x78
IP	IP20 once installed in panel, unit is splash proof and can be installed outdoors as long as no direct sunlight hits it

### 8 CASE DIMENSIONS

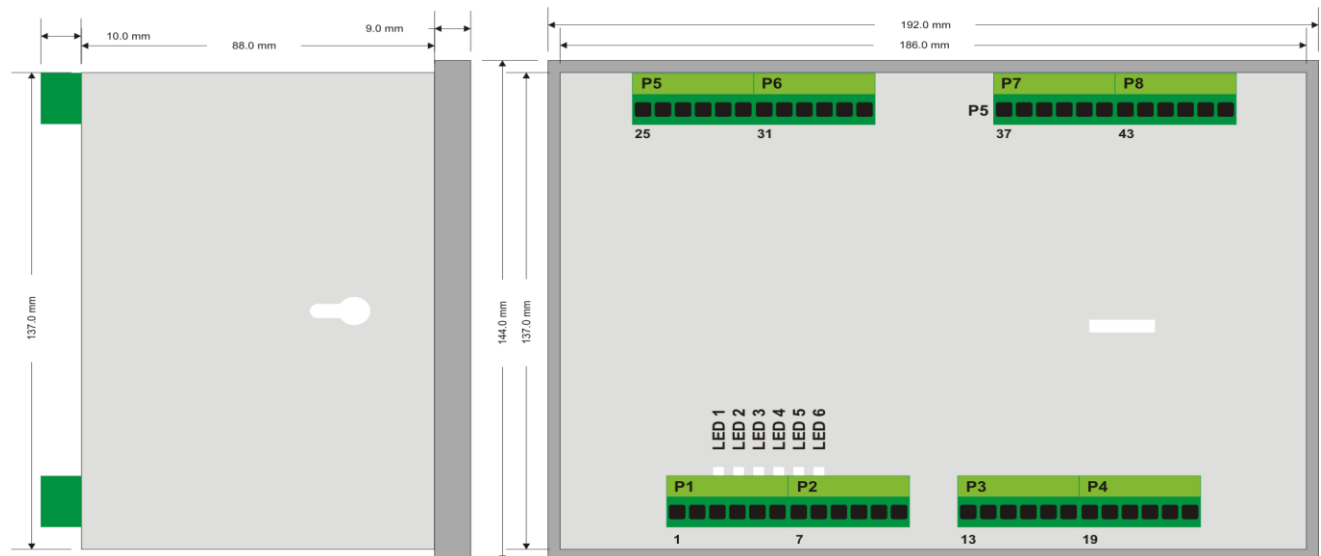

### 9 TYPICAL WIRING DIAGRAM

Refer to attachment.

<sup>1</sup> In AUTO mode with Mains ON.

DC Inputs / Outputs with Contactors  
OmegaATSWiring-MGG DC\_IO.Sch



DC Inputs / Outputs with MCB  
OmegaATSWiring-MGG DC\_IO\_MCB.Sch



AC Inputs  
OmegaATSWiring-MGG AC\_I.Sch



AC OUTPUTS with Contactors  
OmegaATSWiring-MGG AC\_O.Sch



AC OUTPUTS with MCB  
OmegaATSWiring-MGG AC\_O\_MCB.Sch



# OMEGA ATS/ATSO WIRINGS FOR MAIN AND 2 GENERATORS - MGG

S & A.S. Ltd.  
BOUTROS BLDG. 1ST BSMT  
CHEIKH-EL-GHABY ST.  
2068 7808 GHABY - BEIRUT - LEBANON  
TEL : 01-216994

Omega-ATS/ATSO Wiring Diagrams - MGG

Size B	FCSM No.	DWG No.	Rev 1
-----------	----------	---------	----------

Scale	Sheet 1 of 6
-------	-----------------



### DC side Inputs / Outputs with Contactors

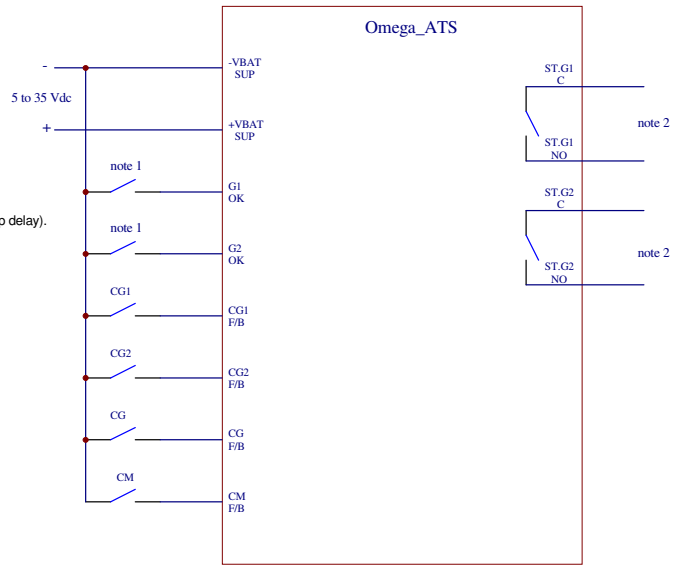

**Note 1:** External contact supplied from the autostart of the genset:  
 Contact closed: Genset is running & ready to supply the load (no need for warm-up delay).  
 Contact open: Genset has a fault or cannot supply the load.

**Note 2:** Should be connected to the remote control terminals of the autostart of the genset.  
 Contact closed: Genset should start (no need for response delay).  
 Contact open: Genset should shutdown (no need for cooling delay).

S & A S. Ltd. BOUTROS BLDG. 1ST BSMT CHEIKH-EL-GHABY ST. 2068 7808 GHABY - BEIRUT - LEBANON TEL : 01-216994			
Omega-ATS Wiring Diagram - DC Inputs+Outputs			
Size B	FCSM No.	DWG No. OmegaATSWiring-MGG_DC_IO.Sch	Rev 1
Scale		Sheet 2 of 6	

### DC side Inputs / Outputs with MCB

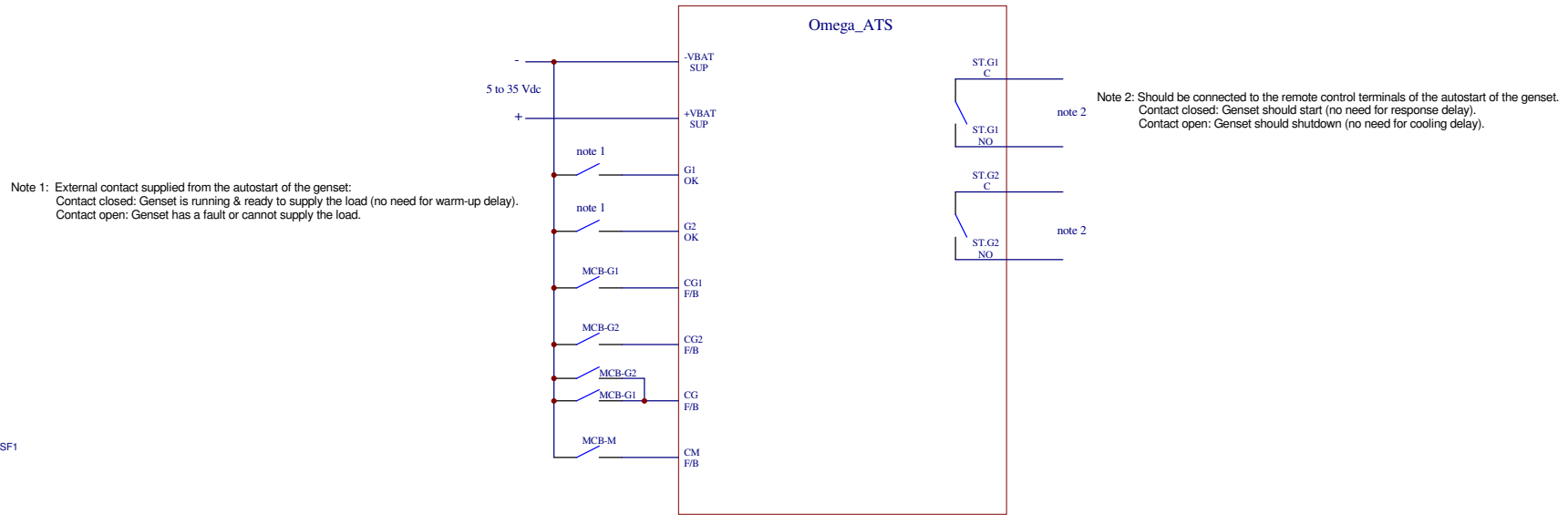

S & A.S. Ltd.  
 BOUTROS BLDG. 1ST BSMT  
 CHEIKH-EL-GHABY ST.  
 2068 7808 GHABY - BEIRUT - LEBANON  
 TEL : 01-216994

Omega-ATS Wiring Diagram - DC Inputs+Outputs - MCB

Size B	FCSM No.	DWG No. OOmegaATSWiring-MGG_DC_IO_MCB.Sch	Rev 1
Scale		Sheet 3 of 6	

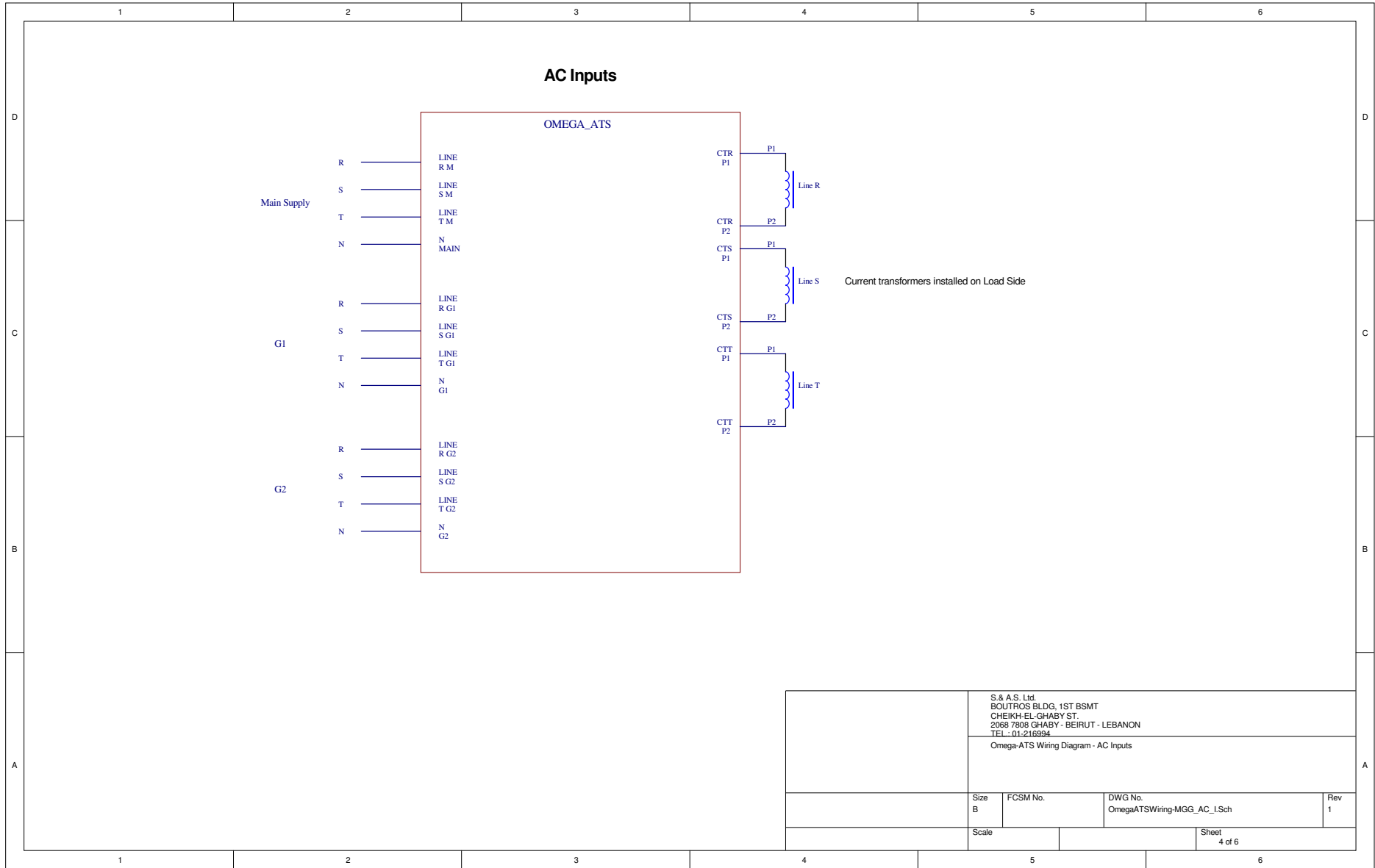

S & A.S. Ltd.  
 BOUTROS BLDG. 1ST BSMT  
 CHEIKH-EL-GHABY ST.  
 2068 7808 GHABY - BEIRUT - LEBANON  
 TEL : 01-216994

Omega-ATS Wiring Diagram - AC Inputs

Size B	FCSM No.	DWG No. OmegaATSWiring-MGG_AC_I.Sch	Rev 1
Scale		Sheet 4 of 6	

### AC OUTPUTS with Contactors

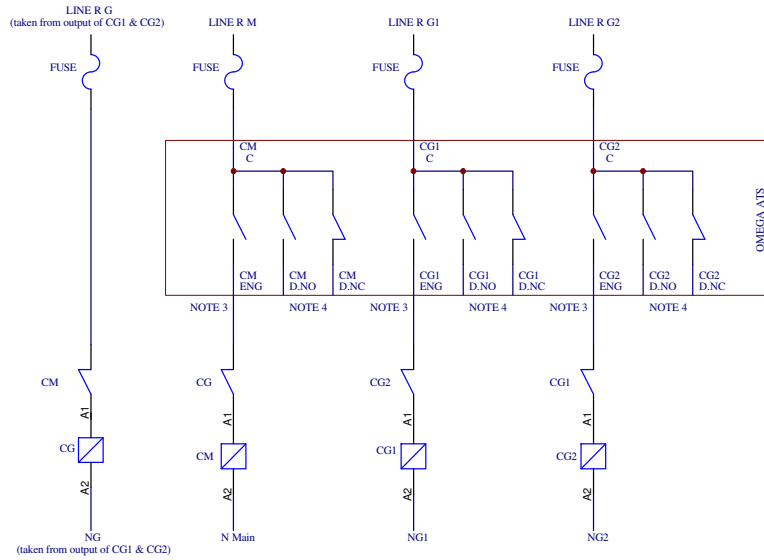

=> This wiring diagram is for 4-poles contactors.  
 => 3-poles contactors can be used if it is acceptable to connect the neutrals of the Mains, G1 & G2 together.

Note 3: For use with motorized circuit breaker to engage it.  
 Note 4: For use with motorized circuit breaker to disengage it.

### Single line diagram

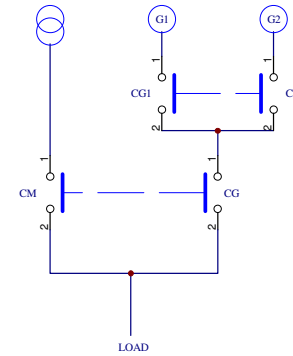

LOAD

S & A.S. Ltd.  
 BOUTROS BLDG. 1ST BSMT  
 CHEIKH-EL-GHABY ST.  
 2068 7808 GHABY - BEIRUT - LEBANON  
 TEL : 01-216994

Omega-ATS Wiring Diagram - AC Outputs - Contactors

Size B	FCSM No.	DWG No. OmegaATSWiring-MGG_AC_O.Sch	Rev 1
Scale		Sheet 5 of 6	

### AC OUTPUTS with MCB

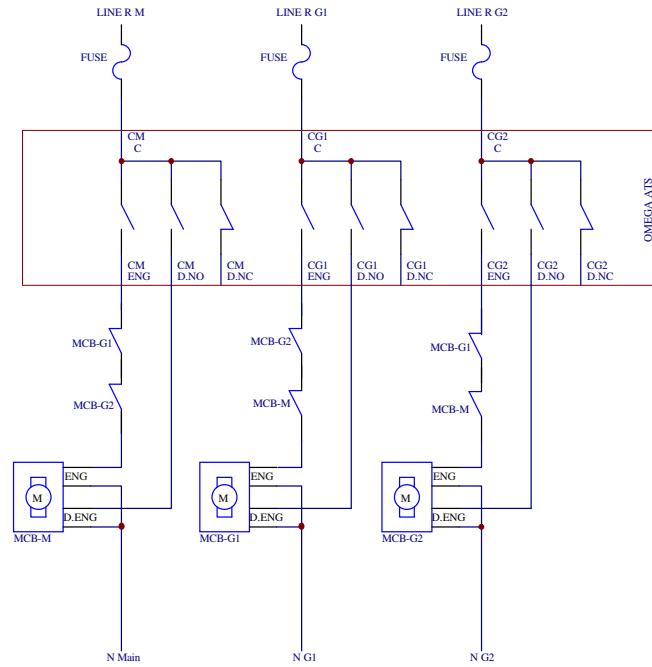

### Single line diagram

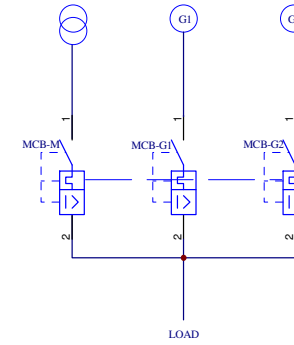

S & A.S. Ltd.  
 BOUTROS BLDG. 1ST BSMT  
 CHEIKH-EL-GHABY ST.  
 2068 7808 GHABY - BEIRUT - LEBANON  
 TEL : 01-216994

Omega-ATS Wiring Diagram - AC Outputs - MCB

Size B	FCSM No.	DWG No. OmegaATSWiring-MGG_AC_O_MCB.Sch	Rev 1
Scale		Sheet 6 of 6	

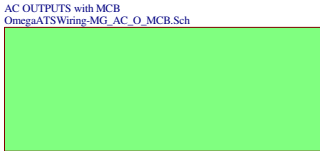
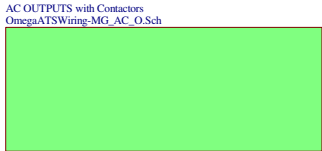
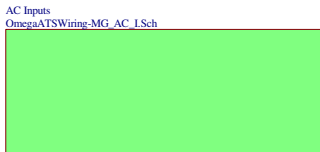
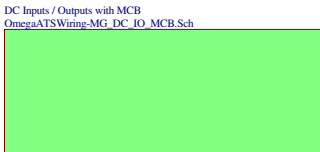
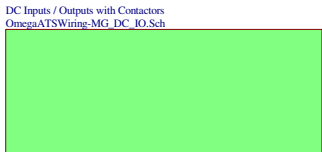

# OMEGA ATS/ATSO WIRINGS FOR MAIN AND 1 GENERATOR - MG

S & A.S. Ltd. BOUTROS BLDG. 1ST BSMT CHEIKH-EL-GHABY ST. 2068 7808 GHABY - BEIRUT - LEBANON TEL : 01-216994			
Omega-ATS/ATSO Wiring Diagrams - MG			
Size B	FCSM No.	DWG No.	Rev 1
Scale		Sheet 1 of 6	

### DC side Inputs / Outputs with Contactors

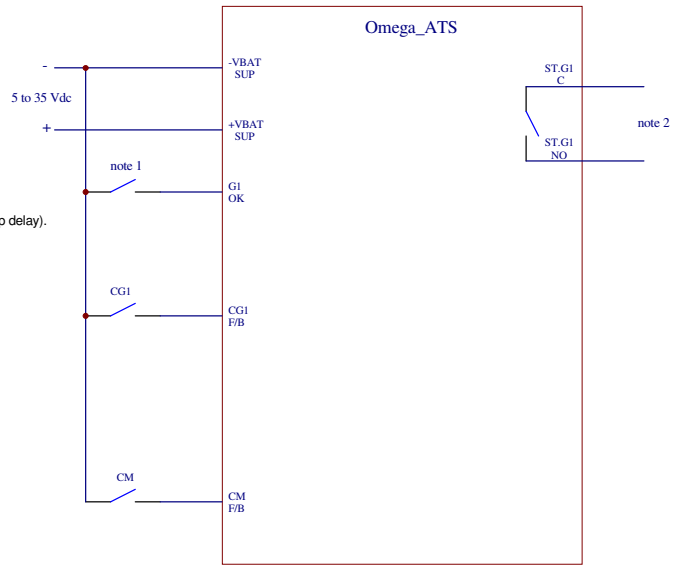

**Note 1:** External contact supplied from the autostart of the genset:  
 Contact closed: Genset is running & ready to supply the load (no need for warm-up delay).  
 Contact open: Genset has a fault or cannot supply the load.

**Note 2:** Should be connected to the remote control terminals of the autostart of the genset.  
 Contact closed: Genset should start (no need for response delay).  
 Contact open: Genset should shutdown (no need for cooling delay).

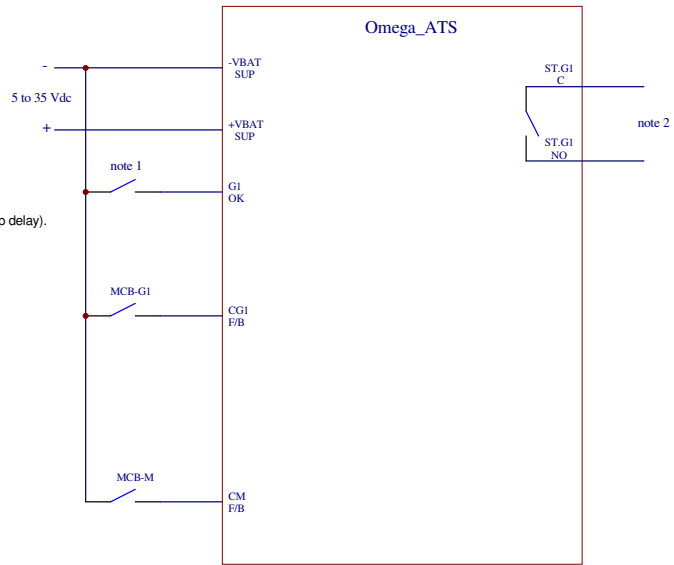

OmegaATSWiring AC I OmegaATSWiring AC O		S & A.S. Ltd. BOUTROS BLDG. 1ST BSMT CHEIKH-EL-GHABY ST. 2068 7808 GHABY - BEIRUT - LEBANON TEL : 01-216994		
Omega-ATS Wiring Diagram - DC Inputs+Outputs				
Size B	FCSM No.	DWG No. OmegaATSWiring-MG_DC_IO.Sch	Rev 1	
Scale		Sheet 2 of 6		

### DC side Inputs / Outputs with MCB



**Note 1:** External contact supplied from the autostart of the genset:  
 Contact closed: Genset is running & ready to supply the load (no need for warm-up delay).  
 Contact open: Genset has a fault or cannot supply the load.

**Note 2:** Should be connected to the remote control terminals of the autostart of the genset.  
 Contact closed: Genset should start (no need for response delay).  
 Contact open: Genset should shutdown (no need for cooling delay).

 		S & A.S. Ltd. BOUTROS BLDG. 1ST BSMT CHEIKH-EL-GHABY ST. 2068 7808 GHABY - BEIRUT - LEBANON TEL : 01-216994		
		Omega-ATS Wiring Diagram - DC Inputs+Outputs		
Size B	FCSM No.	DWG No. OmegaATSWiring-MG_DC_IO_MCB.Sch	Rev 1	
Scale				Sheet 3 of 6



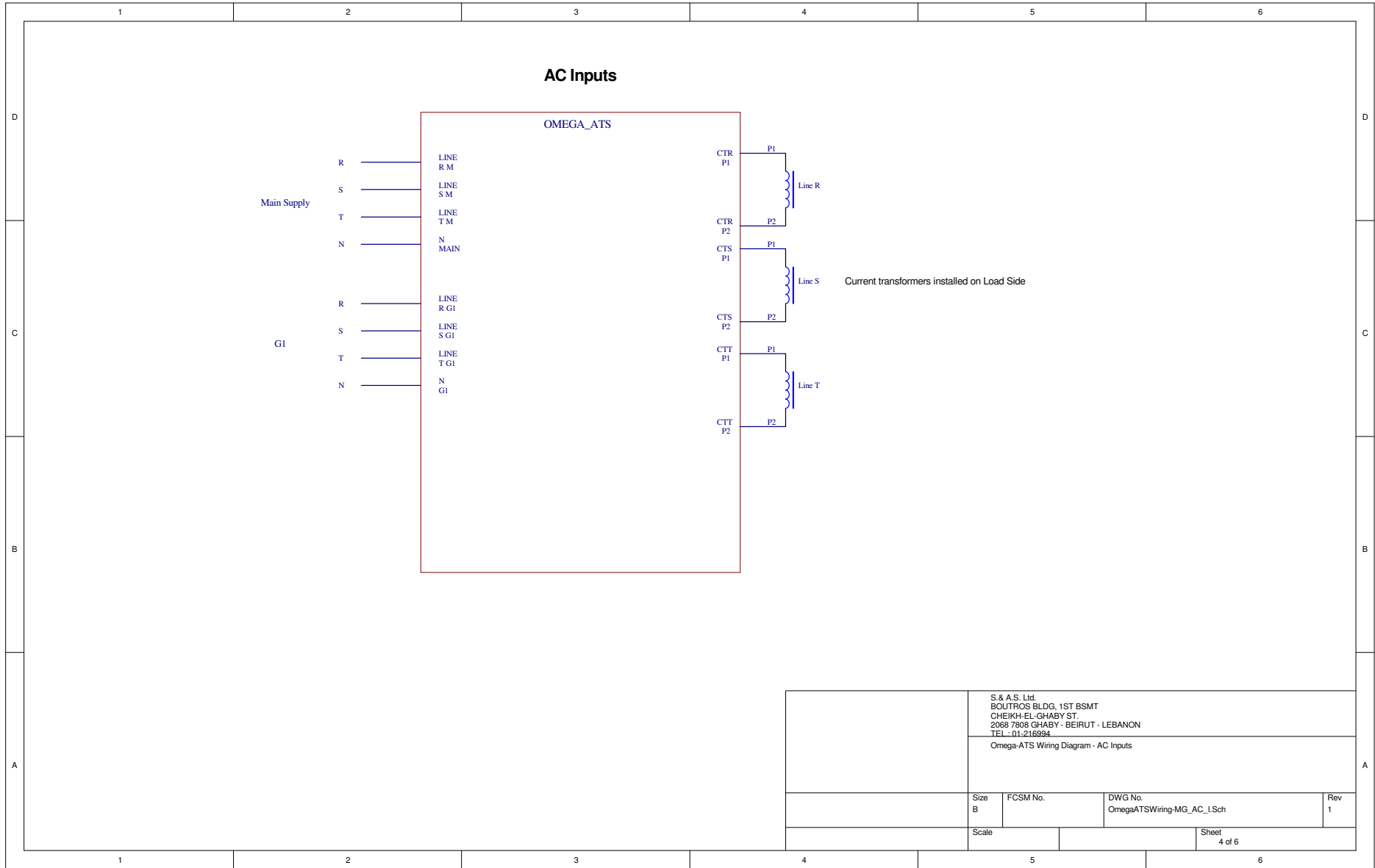

### AC OUTPUTS with Contactors

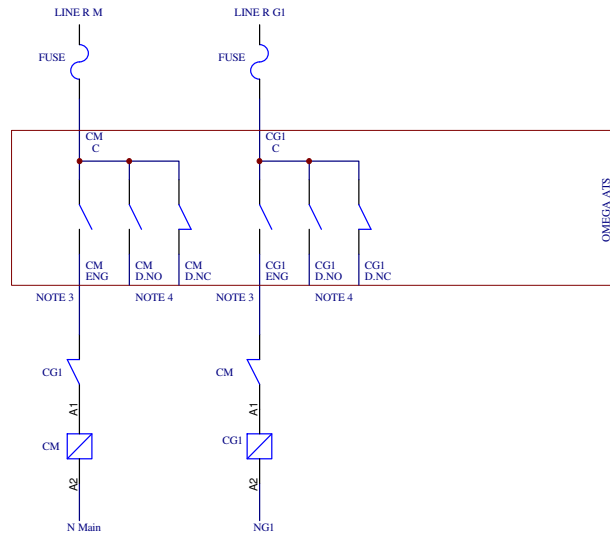

=> This wiring diagram is for 4-poles contactors.  
 => 3-poles contactors can be used if it is acceptable to connect the neutrals of the Mains, G1 & G2 together.

Note 3: For use with motorized circuit breaker to engage it.

Note 4: For use with motorized circuit breaker to disengage it.

### Single line diagram

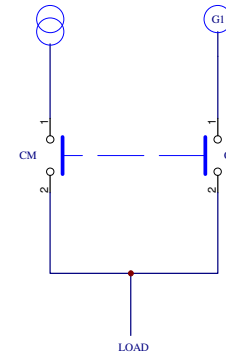

LOAD

S & A S. Ltd.  
 BOUTROS BLDG. 1ST BSMT  
 CHEIKH-EL-GHABY ST.  
 2068 7808 GHABY - BEIRUT - LEBANON  
 TEL : 01-216994

Omega-ATS Wiring Diagram - AC Outputs - Contactors

Size B	FCSM No.	DWG No. OmegaATSWiring-MG_AC_O.Sch	Rev 1
Scale		Sheet 5 of 6	

### AC OUTPUTS with MCB

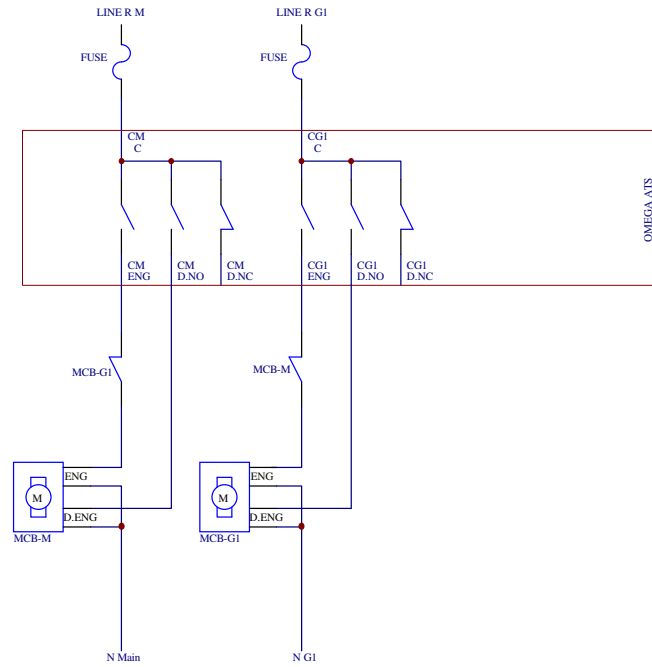

### Single line diagram

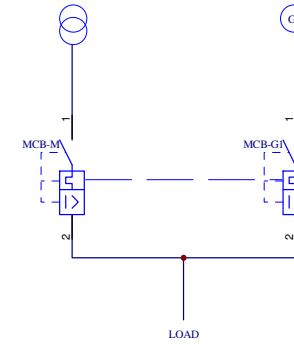

S & A.S. Ltd.  
 BOUTROS BLDG. 1ST BSMT  
 CHEIKH-EL-GHABY ST.  
 2068 7808 GHABY - BEIRUT - LEBANON  
 TEL : 01-216994

Omega-ATS Wiring Diagram - AC Outputs - MCB

Size B	FCSM No.	DWG No. OmegaATSWiring-MG_AC_O_MCB.Sch	Rev 1
Scale		Sheet 6 of 6	



DC Inputs / Outputs with Contactors  
OmegaATSWiring-GG\_DC\_IO.Sch

DC Inputs / Outputs with MCB  
OmegaATSWiring-GG\_DC\_IO\_MCB.Sch

AC Inputs  
OmegaATSWiring-GG\_AC\_I.Sch

AC OUTPUTS with Contactors  
OmegaATSWiring-GG\_AC\_O.Sch

AC OUTPUTS with MCB  
OmegaATSWiring-GG\_AC\_O\_MCB.Sch

# OMEGA ATS/ATSO WIRINGS FOR 2 GENERATORS - GG

				S & A.S. Ltd. BOUTROS BLDG. 1ST BSMT CHEIKH-EL-GHABY ST. 2068 7808 GHABY - BEIRUT - LEBANON TEL : 01-216994			
				Omega-ATS/ATSO Wiring Diagrams - GG			
Size	FCSM No.	DWG No.	Rev				
B		OmegaATSWiring_GG.Sch	1				
Scale				Sheet		1 of 6	

### DC side Inputs / Outputs with Contactors

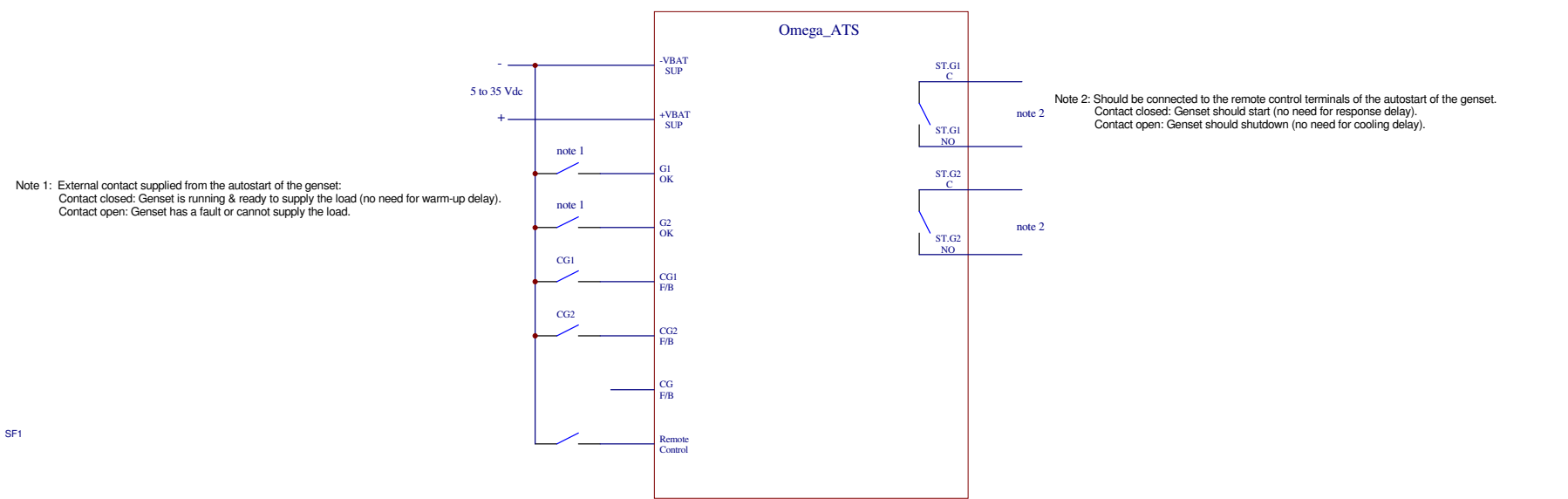

S & A S. Ltd. BOUTROS BLDG. 1ST BSMT CHEIKH-EL-GHABY ST. 2068 7808 GHABY - BEIRUT - LEBANON TEL : 01-216994			
Omega-ATS Wiring Diagram - DC Inputs+Outputs			
Size B	FCSM No.	DWG No. OmegaATSWiring-GG_DC_IO.Sch	Rev 1
Scale		Sheet 2 of 6	

### DC side Inputs / Outputs with MCB

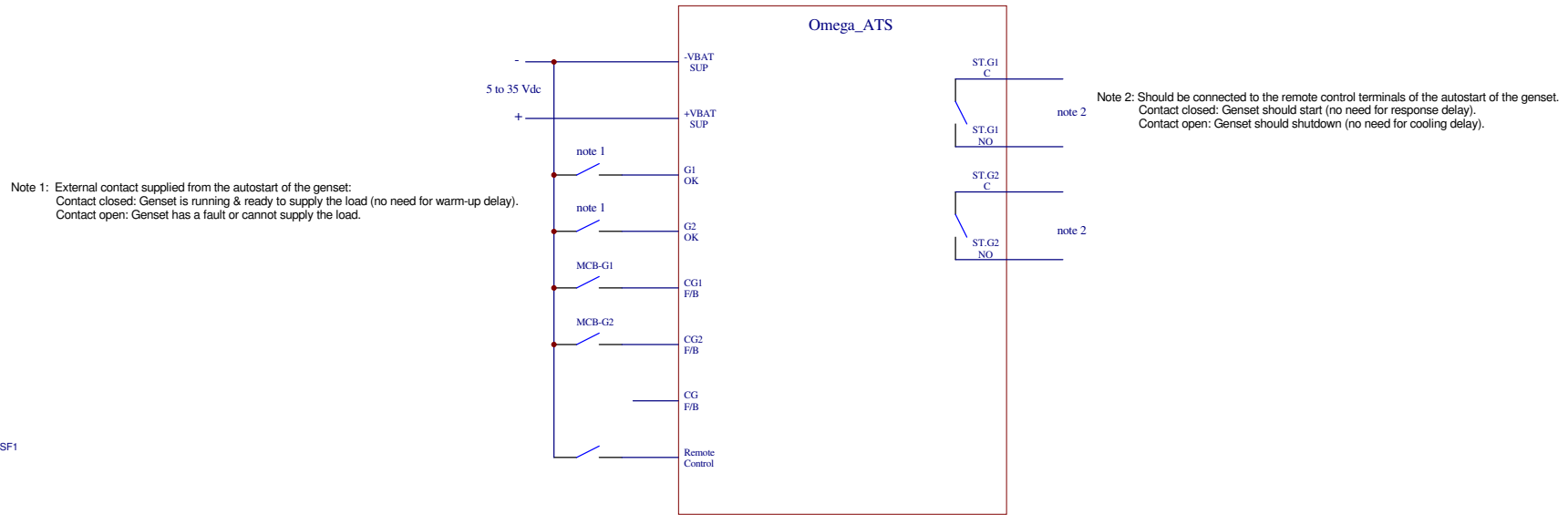

S & A S. Ltd.  
 BOUTROS BLDG. 1ST BSMT  
 CHEIKH-EL-GHABY ST.  
 2068 7808 GHABY - BEIRUT - LEBANON  
 TEL : 01-216994

Omega-ATS Wiring Diagram - DC Inputs+Outputs

Size B	FCSM No.	DWG No. OmegaATSWiring-GG_DC_IO_MCB.Sch	Rev 1
Scale		Sheet 3 of 6	

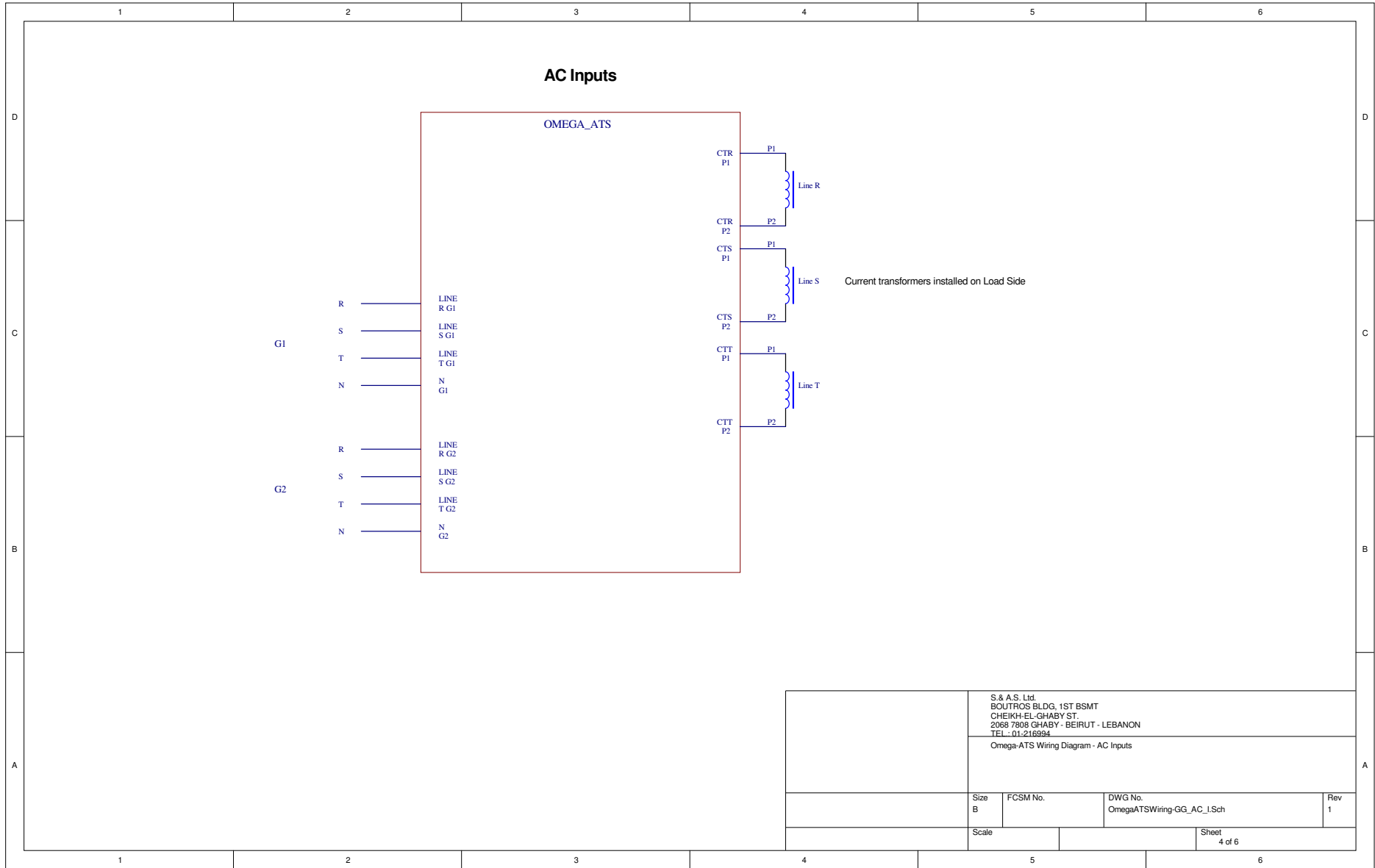

S & A.S. Ltd.  
 BCUTROS BLDG. 1ST BSMT  
 CHEIKH-EL-GHABY ST.  
 2068 7808 GHABY - BEIRUT - LEBANON  
 TEL : 01-216994

Omega-ATS Wiring Diagram - AC Inputs

Size B	FCSM No.	DWG No. OmegaATSWiring-GG_AC_I.Sch	Rev 1
Scale		Sheet 4 of 6	

## AC OUTPUTS with Contactors

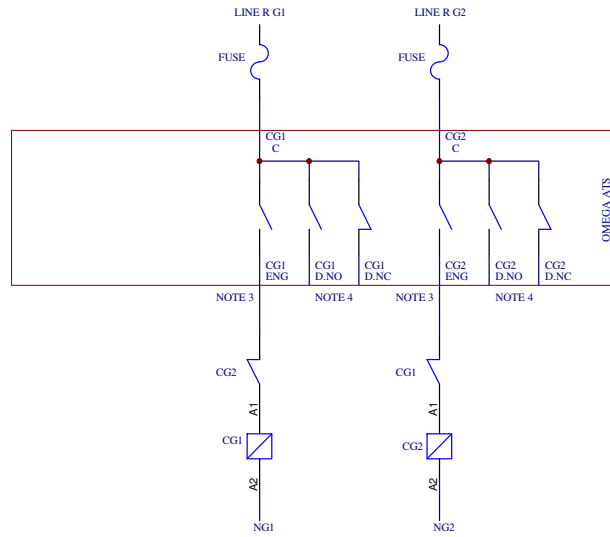

=> This wiring diagram is for 4-poles contactors.  
 => 3-poles contactors can be used if it is acceptable to connect the neutrals of the Mains, G1 & G2 together.

Note 3: For use with motorized circuit breaker to engage it.

Note 4: For use with motorized circuit breaker to disengage it.

## Single line diagram

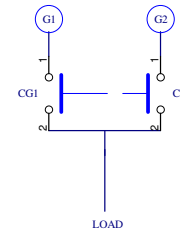

S & A.S. Ltd.  
 BOUTROS BLDG. 1ST BSMT  
 CHEIKH-EL-GHABY ST.  
 2068 7808 GHABY - BEIRUT - LEBANON  
 TEL : 01-216994

Omega-ATS Wiring Diagram - AC Outputs - Contactors

Size B	FCSM No.	DWG No. OmegaATSWiring-GG_AC_O.Sch	Rev 1
-----------	----------	---------------------------------------	----------

Scale	Sheet 5 of 6
-------	-----------------



### AC OUTPUTS with MCB

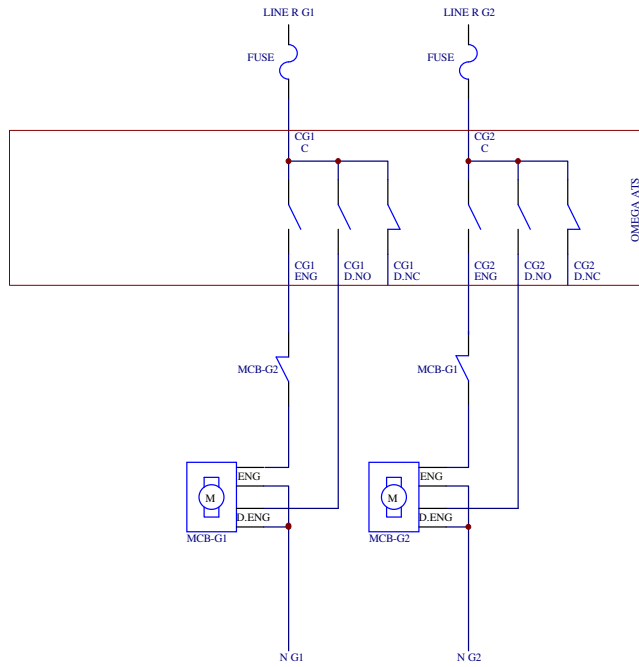

### Single line diagram

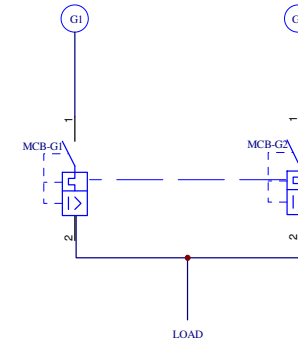

S & A.S. Ltd.  
 BOUTROS BLDG. 1ST BSMT  
 CHEIKH-EL-GHABY ST.  
 2068 7808 GHABY - BEIRUT - LEBANON  
 TEL : 01-216994

Omega-ATS Wiring Diagram - AC Outputs - MCB

Size B	FCSM No.	DWG No. OmegaATSWiring-GG_AC_O_MCB.Sch	Rev 1
Scale		Sheet 6 of 6	