



**S. & A.S. LTD**

## **INTELLIGENT ELEVATOR RESCUE DEVICE CONTROLLER**



### **USER'S MANUAL**

FOR S/W VERSION 1.0  
0929

**Beirut Office:**  
Boutros Building 1<sup>st</sup> Basement  
Cheikh-el-Ghabi Street  
Ghabi Beirut 2068 7808  
Lebanon  
Tel: +961 1 216 994  
Fax: +961 1 339 600

**Headquarters & Factory:**  
S. & A. S. Building  
Seaside Road  
Jieh Chouf  
Lebanon  
Tel: +961 7 996 333  
Fax: +961 7 996 116

**Website:**  
[www.sascontrollers.com](http://www.sascontrollers.com)

**Technical Support & Email:**  
Tel: +961 71 996 333  
[support@sascontrollers.com](mailto:support@sascontrollers.com)

- 1 OVERVIEW ..... 3
  - MAIN FEATURES ..... 3
  - 1.2 TECHNICAL DATA ..... 3
- 2 GENERAL DESCRIPTION ..... 3
  - 2.1 OPERATION ..... 3
  - 2.2 INSTALLATION ..... 4
  - 2.3 EVACUATION MODES ..... 4
    - 2.3.1 STANDALONE ..... 4
    - 2.3.2 INTEGRATED AC2 SPD ..... 4
    - 2.3.3 INTEGRATED VX2 ..... 4
- 3 CONTENTS OF PAGES DISPLAYED ON DIAGNOSTIC TOOL ..... 4
- 4 VIEWING FAULTS AND FAULTS DESCRIPTION ..... 4
  - 4.1 HOW TO VIEW THE FAULTS ..... 4
  - 4.2 HOW TO ERASE THE FAULTS ..... 5
  - 4.3 FAULT CODE DESCRIPTION ..... 6
- 5 MENU ..... 6
  - 5.1 ACCESSING THE MENU ..... 6
    - 5.1.1 MAIN MENU DESCRIPTION ..... 6

## 1 OVERVIEW

The Rescue device is a versatile and simple yet very effective elevator evacuation system controller. It comprises a single-phase sine wave inverter, a three-phase space vector modulated inverter and a state of the art battery charger that automatically switches between four operating modes depending of the battery charge level. The switching frequency of the inverters is 10KHz. The switching frequency of the charger is 20KHz. The four operating modes of the charger are: trickle (for depleted batteries), bulk (for discharged batteries), float (overcharging) and full (for maintaining battery charge). Ease of installation, adjustment and operation in addition to excellent performance and reliability are the strong points of this controller. To maintain battery charge, the Rescue will switch to a zero power consumption mode following a rescue operation or if it is in standby mode and the utility is absent.

### 1.1 MAIN FEATURES

Platform	Digital Signal Processor
Type	Space Vector Modulation on 10KHz frequency
Charger Modes	Trickle, bulk, float or full
Self diagnostic	Fault messages describing common faults
Measured values	Battery voltage Battery charge current Single phase inverter current Three phase inverter current
User interface	Separate diagnostic tool with a 24 character, 2 lines liquid crystal display

### 1.2 TECHNICAL DATA

Supply voltages	50 to 94Vdc
Line frequency	45Hz to 65Hz
Single Phase Current Rating	10Arms on 50Vrms
Three Phase Current rating	10Arms for Rescue, 25Arms for RescueHP
Switching freq. Of inverters	10KHz
Modulation	Space vector
Output freq. of 3-phase inverter	0 to 9.9Hz
Control inputs	Each input has a led to indicate its status – all inputs are optically isolated Active high
Periphery Supply	22Vdc – 100mA
Control outputs	Relay outputs: 10A 250vac Optocoupler outputs: 50mA 50vdc
Connection	Screw type, plug-in connectors

## 2 GENERAL DESCRIPTION

### 2.1 OPERATION

The Rescue device has two operating modes: **standby** and **ready** selected by a switch on **IN4**, terminal **P1.6**:

**Standby**: the controller will not intervene in case of a power failure. Switching to **Standby** mode will abort any rescue operation in progress. It also resets any error that occurred during a rescue operation. Of course, the battery charging remains operational at all times as long as there is power available. The controller switches to zero power consumption mode when the utility fails. It will automatically resume charging of batteries when the utility is restored.

**Ready**: the battery charger is enabled as long as there is power available. Upon a power failure and if the **DZ** input is active, the controller will not intervene for a swinging door. On the other hand, for automatic doors, the controller will intervene after the elapse of the time set by **Response** to open it if the “limit switch end of opening” is not open. If **LS override delay** is set different than zero, the controller will intervene in all cases and will activate the door open for the time set. If **DZ** (**IN2** on terminal **P1.4**) is not active, the controller will behave as follows and depending of the **Evacuation Mode** chosen:

1. **Standalone** or **Integrated AC2 spd**: the motor contactor is energized. If the safety circuit is closed, the contactor engages. This is detected by input **IN1** on terminal **P1.3**. DC injection is initiated and the mechanical brake is released (contact on terminals **p2.5** and **p2.6**). The controller will attempt to move the elevator in both directions and chooses the direction that draws the least amount of current to continue its travel until a floor level is reached. The floor level is signaled by input **DZ**. DC injection and mechanical brake are engaged simultaneously and after the elapse of the **DZ override delay** timer.

2. **Integrated VX2**: this evacuation mode relies on the VX2 VVVF drive to control the elevator motor. When the **DZ** becomes active, the rescue controller will take over and opens the door in case it is an automatic door.

In all cases and after completion of the evacuation cycle, the controller will switch to zero power consumption mode. It will automatically resume normal operation and charging of batteries when the utility is restored. Please note that it is not possible to use the diagnostic tool when the controller is in zero power consumption mode. To enable the use of the diagnostic tool in this mode, place a jumper on JP5. To preserve the batteries, please remember to remove this jumper when the diagnostic tool is no longer needed. If the utility is available, the diagnostic tool will work regardless of JP5.

## 2.2 INSTALLATION

Wiring diagrams for the three evacuation modes with different door types are attached to this document. Implement the proper wiring diagram depending on the evacuation mode selected and door type. Following is a hint on how to set a few key parameters:

1. **Motor Torque**: starting at 60%, increase this parameter until the elevator is able to start with no load at the highest floor, with half load at the middle floor and with full load at the lowest floor. It is advisable to use the minimum value for this parameter that ensures on one end the starting of the elevator and on another end holds the elevator preventing it from accelerating. A Motor Torque value larger than needed could result in permanent damage to the Rescue controller.
2. **LS override delay**: should be set to zero if the **IN3** (terminal **P1.5**) is connected to the **LS\_EO** (limit switch end of opening of the door). Otherwise, it should be set to a value large enough that ensures full opening of the door.
3. **DZ override delay**: adjust the value of this parameter to ensure an accurate stop on the floor level. Make sure that the door zone switches on for no less than 10cm on the floor.

## 2.3 EVACUATION MODES

### 2.3.1 STANDALONE

In this mode, the controller will operate autonomously and will perform the task of evacuation and door opening. No connections with the elevator controller are required except for the safety circuit. No coordination with the main elevator controller is done.

### 2.3.2 INTEGRATED AC2 SPD

In this mode, the evacuation is coordinated very closely with the **ECBAB v3.3** elevator controller. The advantage of such coordination is that the elevator controller keeps track of the floor information. This evacuation mode requires that the elevator controller be powered and operational. Furthermore, it requires the connection of one control signal from the **Rescue** controller (**OUT1** Terminal **P1.7**) to the **SPARE IN2** of the **ECBAB v3.3** controller.

### 2.3.3 INTEGRATED VX2

This evacuation mode requires that a **VX2** VVVF drive be installed with the **ECBAB v3.3** controller. The operation of this mode is similar to the **Integrated ac2 spd** mode with one exception: the **VX2** powers the elevator motor and not the **Rescue** controller.

## 3 CONTENTS OF PAGES DISPLAYED ON DIAGNOSTIC TOOL

Page 1	Company name, Software version
Page 2	- If not in evacuation mode: 1 <sup>st</sup> line: Battery Voltage (Vdc), Charger current (Idc), Mode of charger (trickle, bulk, float or full) 2 <sup>nd</sup> line: Status of the controller (Standby, Ready)
	- In evacuation mode: 1 <sup>st</sup> line: Single phase inverter current (Irms), Three phase inverter current (Irms) 2 <sup>nd</sup> line: Status of evacuation

## 4 VIEWING FAULTS AND FAULTS DESCRIPTION

### 4.1 HOW TO VIEW THE FAULTS

Pressing the middle push button will prompt the board to start displaying the last 10 faults saved in memory. The board begins by displaying the last fault. Press **Previous** push buttons to display the previous fault.

#### 4.2 HOW TO ERASE THE FAULTS

To erase the faults, press on the **Erase** push button while viewing the faults. You will be prompted to confirm your request. If **Yes** is pressed all faults are erased, if **No** is pressed, faults are not affected.

### 4.3 FAULT CODE DESCRIPTION

Fault Message	Fault Description	Action taken
3Ph Power Drive Error	Possible short circuit	Reset by switching to Standby mode
2Ph Power Drive Error	Possible short circuit	Reset by switching to Standby mode
3Ph Over Current Error	Internal transistors over current protection tripped	Reset by switching to Standby mode
2Ph Over Current Error	Internal transistors over current protection tripped	Reset by switching to Standby mode
Safety Open in Travel	Safety circuit opened during travel	Reset by switching to Standby mode
Fail Close Motor C.	Motor contactor failed to close because the safety circuit is open	Reset by switching to Standby mode
Fail Close Door Cont.	Door contactor failed to close	Reset by switching to Standby mode
Max travel time exp.	The <b>Max travel time</b> set in the menu was exceeded before reaching a floor level	Reset by switching to Standby mode
Memory Corrupted	The internal memory is corrupted	Reset by switching to Standby mode

## 5 MENU

### 5.1 ACCESSING THE MENU

To access the menu, press the right most push button on the diagnostic tool. You will be prompted to enter a password (2802). The first digit on the left starts blinking. Use the left most push button to decrement the digit and the middle push button to increment the digit. When the desired digit is reached, push the right most push button. The digit is accepted and replaced by “\*”. The next digit starts blinking. Repeat the above procedure for all remaining three digits. If you have entered the right password, access to the menu will be granted, otherwise access will be denied. Note that the push buttons have dynamic functions and their functions are at all times shown on the lower line of the display. For convenience, entry to the menu does not require the password if it is being accessed within 15 minutes after the last access.

#### 5.1.1 MAIN MENU DESCRIPTION

What you see on the display	Description and Comments	Factory settings	Range
Nbre of 12V bat.	Sets the number of batteries connected	6	1 to 9
Battery Capacity	Sets the capacity of the battery used in AH	7	1 to 99
Response Time (sec)	Sets the time for the Rescue device to intervene upon a power failure	5	0 to 99.9 sec
Door Type	Sets the door type	Swinging	Swinging Auto (3Ph) Auto (DC or VVVF)
Nom. Motor Voltage	Sets the nominal voltage of the lift motor	380	190 to 999V
Nom. Motor Current	Sets the rated current of the lift motor	15	3.1 to 17.0A
DC Brake Current (%)	Sets the DC brake current as a % of the rated current	25	0 to 999
DC brake time start	Sets the DC braking time during start	0.5	0 to 99.9 sec
DC brake time stop	Sets the DC braking time during stop	0.5	0 to 99.9 sec
LS override delay	Sets the override delay when the end of opening limit switch is reached	0	0 to 99.9 sec
DZ override delay	Sets the override delay when the DZ magnet is reached	0.5	0 to 9.99 sec
Nom. Door Voltage	Sets the nominal voltage of the automatic door motor	50	0 to 50V
2Phase Inverter Vrms	Sets the output voltage of the single phase inverter	50	0 to 76V
Evacuation Freq.(Hz)	Sets the frequency of the lift motor during evacuation	5	1 to 9.9Hz
Max travel time	Sets the maximum travel time in minutes during evacuation	2'	5" to 9'59"
Evac. Mode	Sets the operating mode	Standalone	Standalone Integrated ac2spd Integrated VX2
Motor torque (%)	Sets the torque of the lift motor	60%	60 to 150%
Load Factory Settings	Load the values shown under Default Set.	-	N/A
Exit Menu	Select to exit the menu	-	N/A

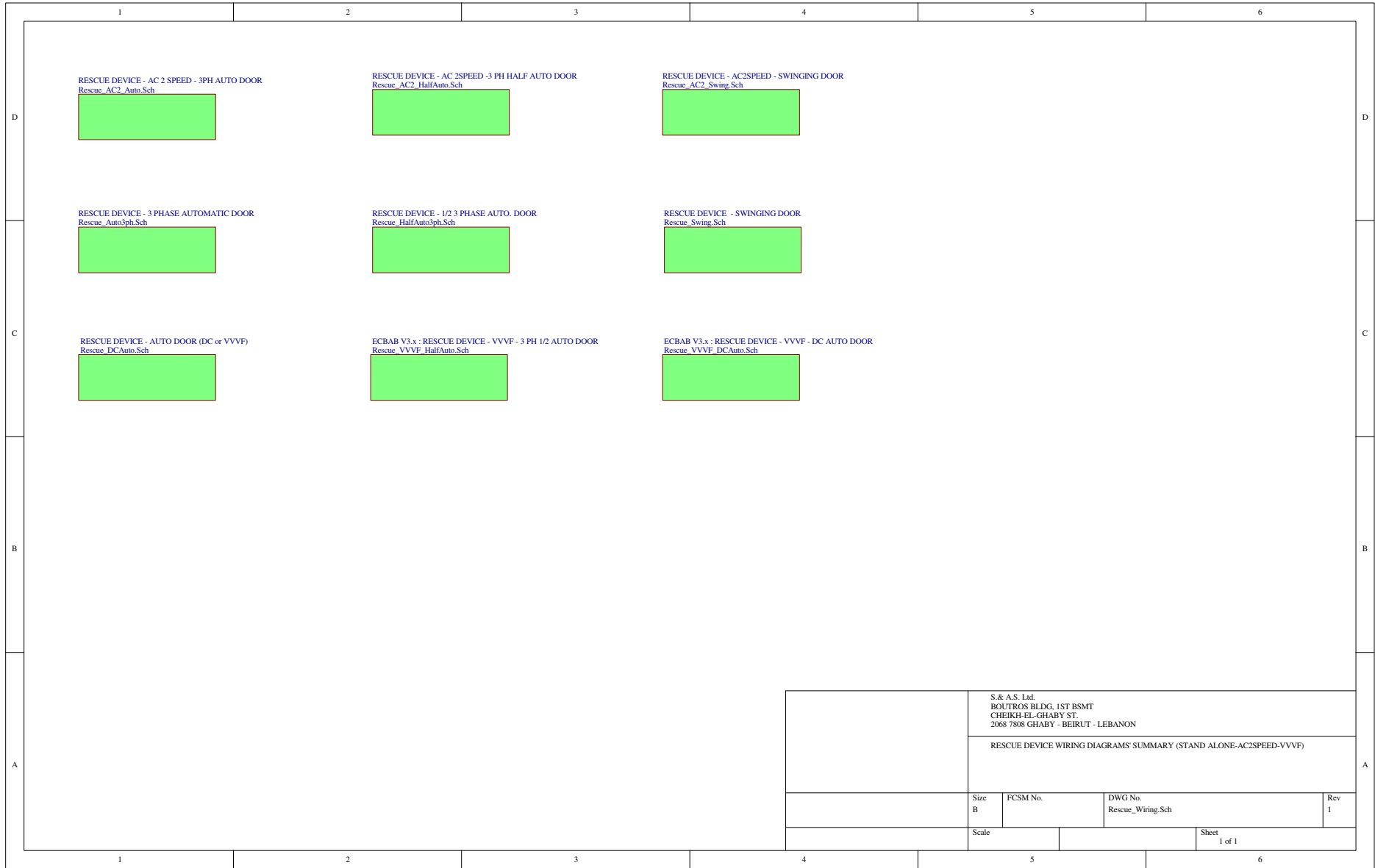

S.& A.S. Ltd.  
 BOUTROS BLDG. 1ST BSMT  
 CHEIKH-EL-GHABY ST.  
 2068 7808 GHABY - BEIRUT - LEBANON

RESCUE DEVICE WIRING DIAGRAMS' SUMMARY (STAND ALONE-AC2SPEED-VVVF)

Size	FCSM No.	DWG No.	Rev
B		Rescue_Wiring.Sch	1
Scale			Sheet
			1 of 1

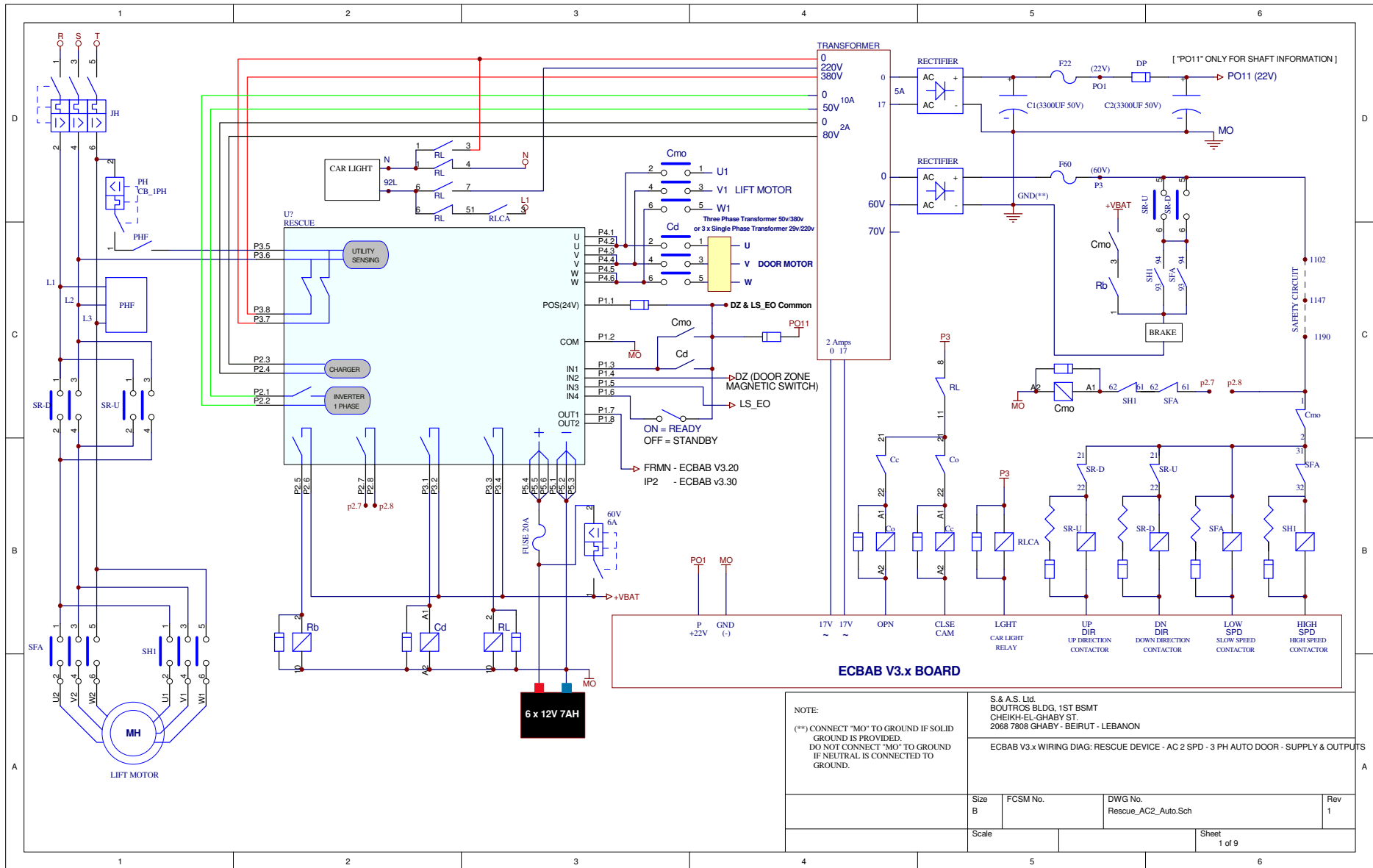



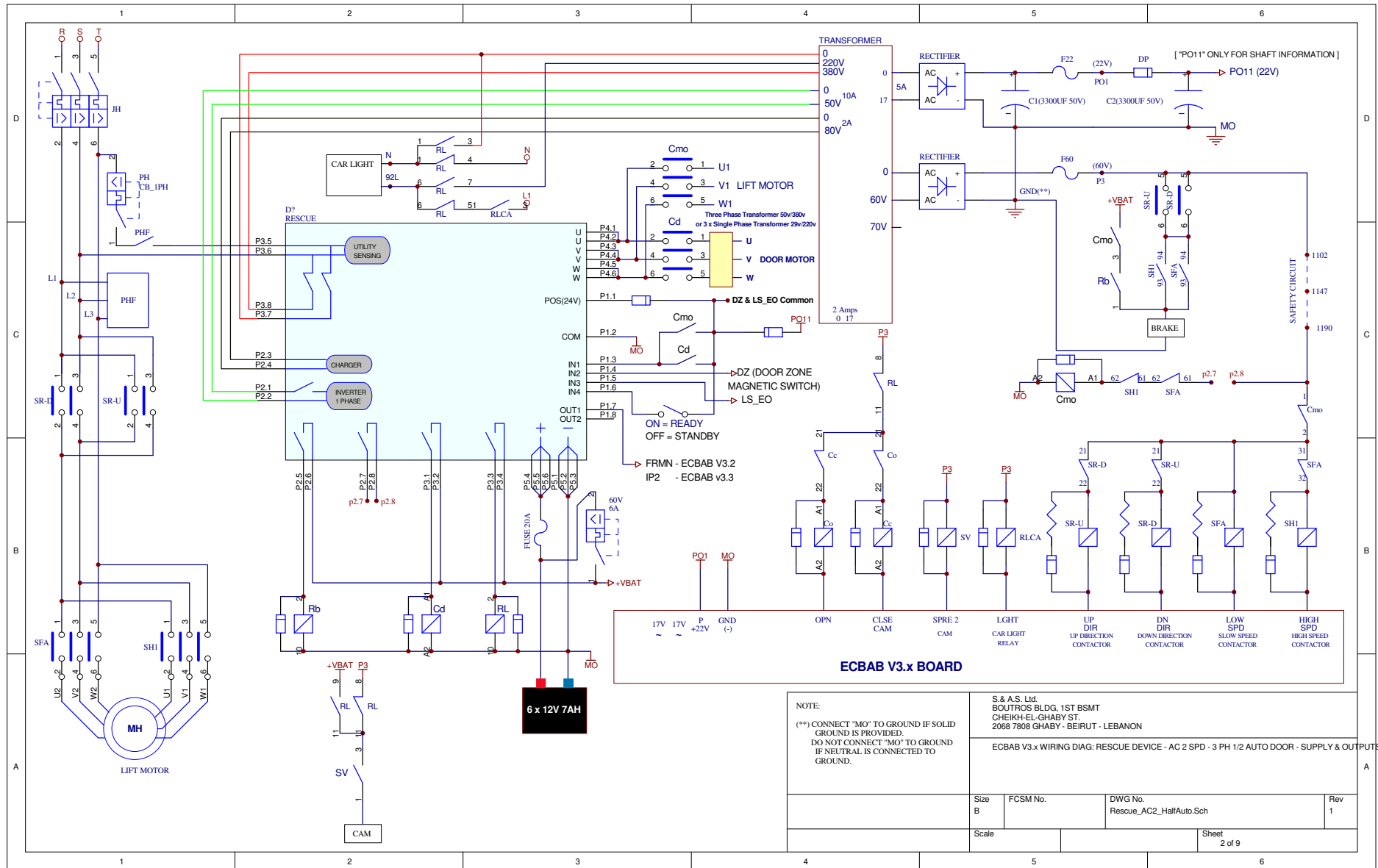

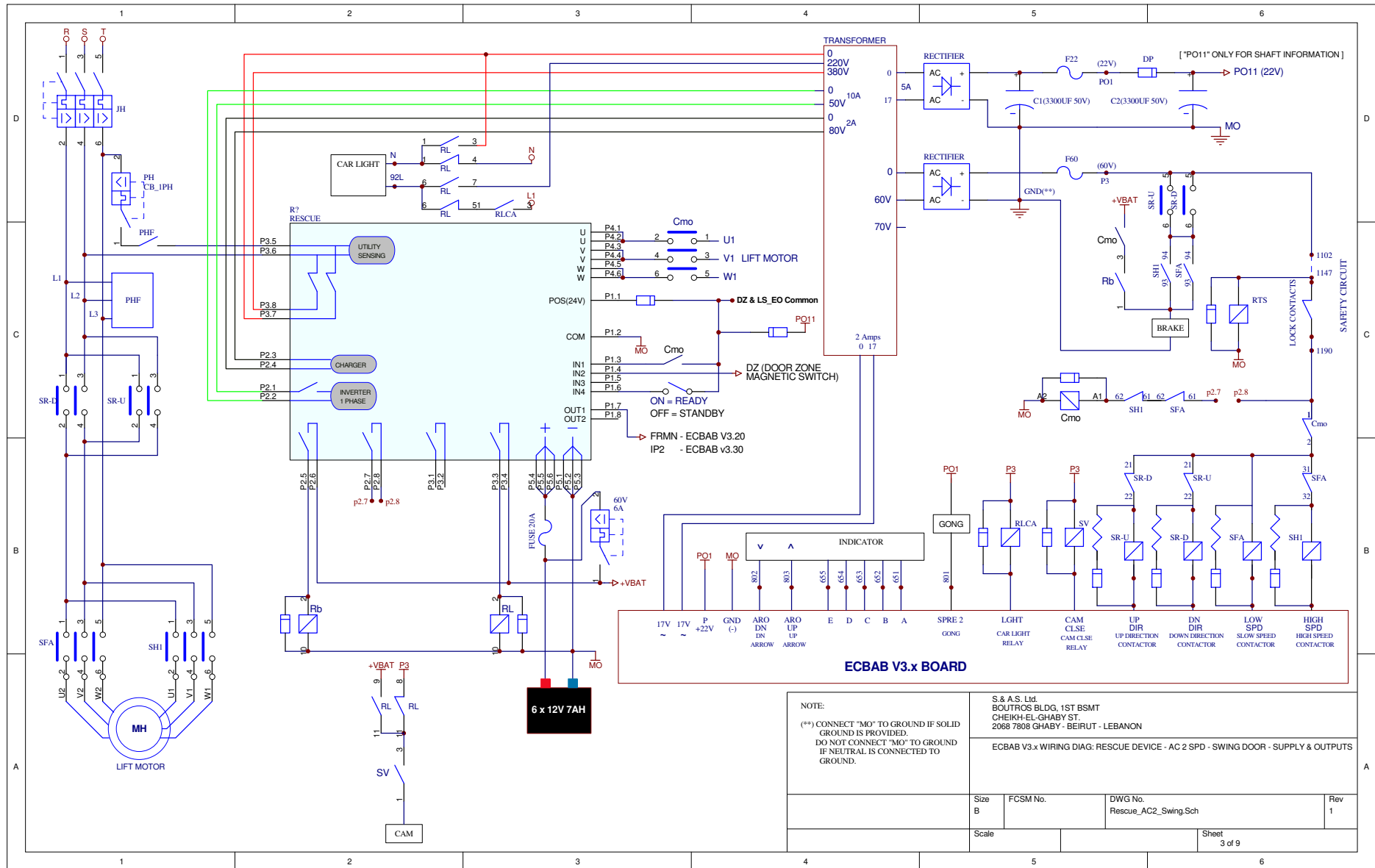

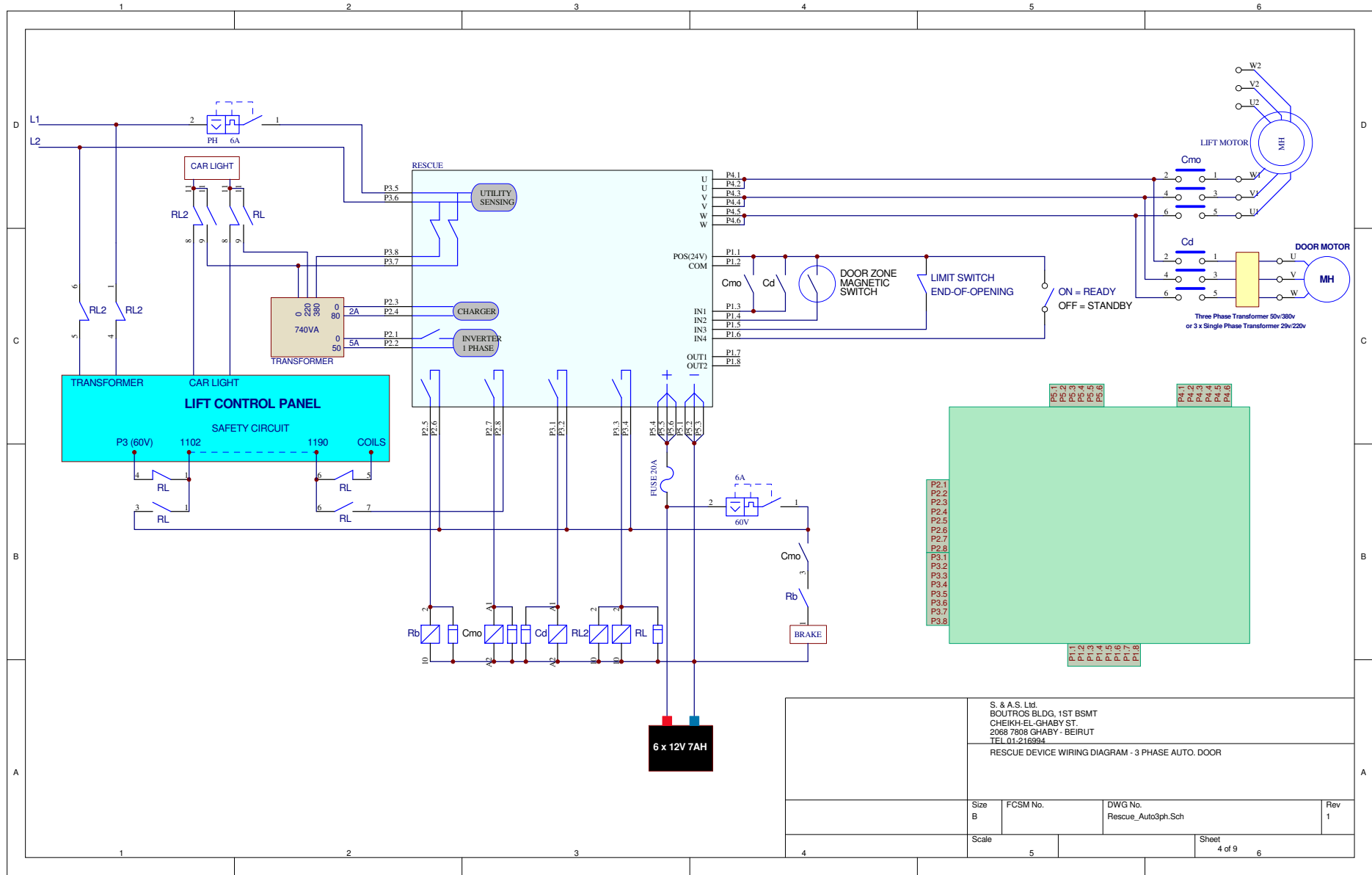

S. & A.S. Ltd. BOUTROS BLDG. 1ST BSMT CHEIKH-EL-GHABY ST. 2068 7808 GHABY - BEIRUT TEL 01-216994			
RESCUE DEVICE WIRING DIAGRAM - 3 PHASE AUTO. DOOR			
Size B	FCSM No.	DWG No. Rescue_Auto3ph.Sch	Rev 1
Scale	5	Sheet 4 of 9	6

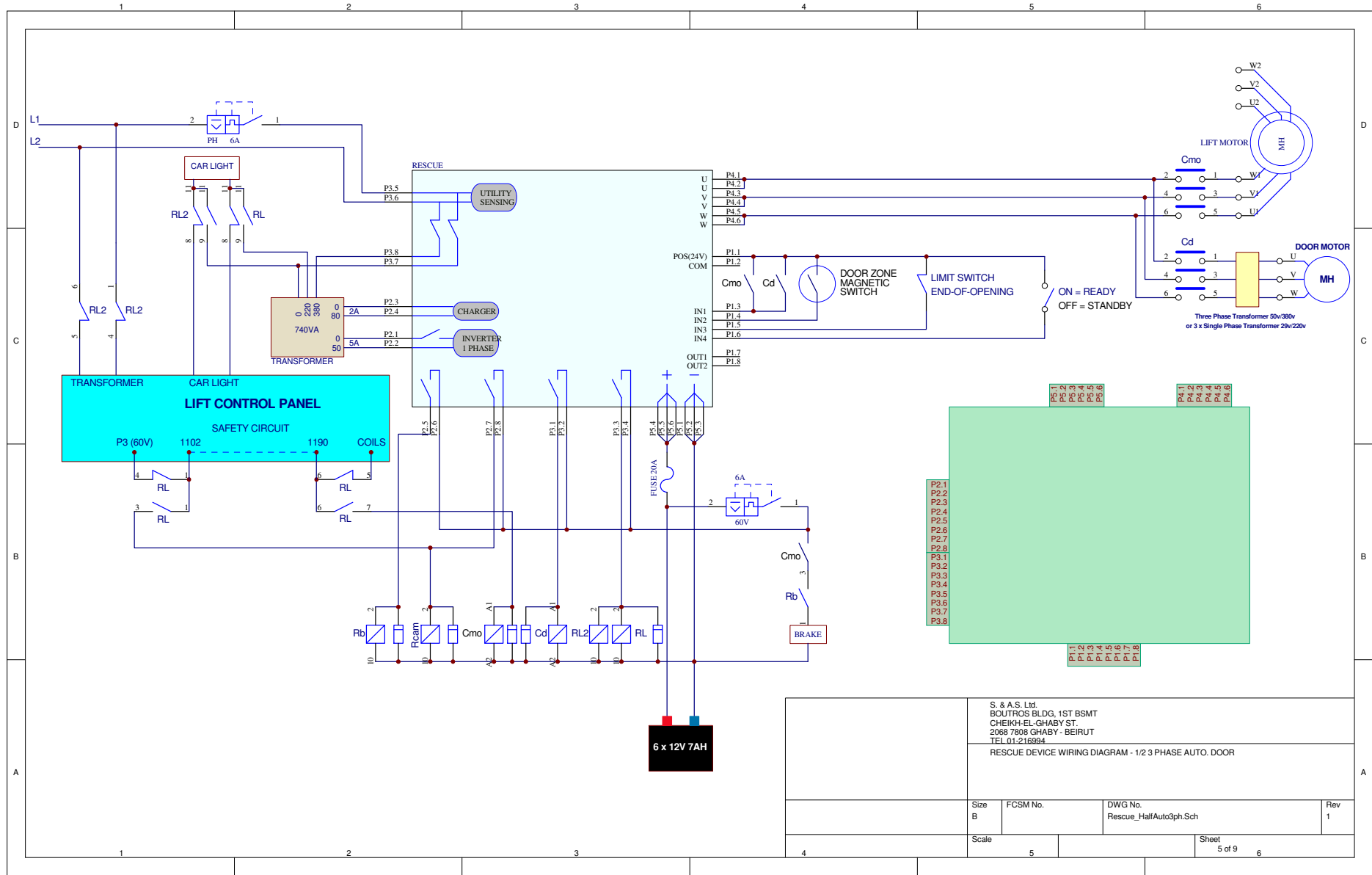

S. & A.S. Ltd. BOUTROS BLDG. 1ST BSMT CHEIKH-EL-GHABY ST. 2068 7808 GHABY - BEIRUT TEL 01-216994			
RESCUE DEVICE WIRING DIAGRAM - 1/2 3 PHASE AUTO. DOOR			
Size B	FCSM No.	DWG No. Rescue_HallAuto3ph.Sch	Rev 1
Scale	5	Sheet 5 of 9	6

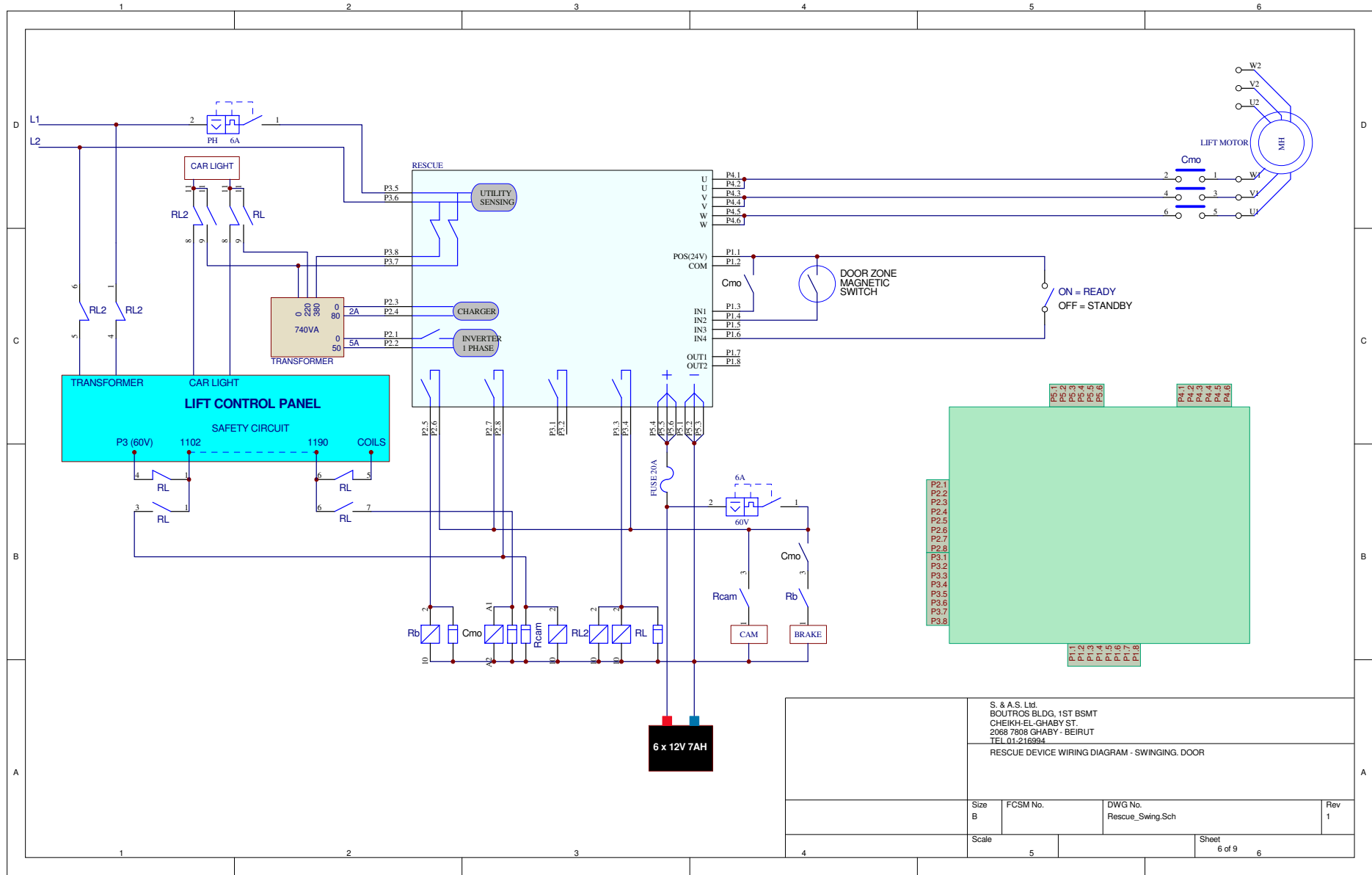

S. & A.S. Ltd.  
 BOUTROS' BLDG. 1ST BSMT  
 CHEIKH-EL-GHABY ST.  
 2068 7808 GHABY - BEIRUT  
 TEL 01-216994

RESCUE DEVICE WIRING DIAGRAM - SWINGING DOOR

Size B	FCSM No.	DWG No. Rescue_Swing_Sch	Rev 1
Scale			Sheet 6 of 9

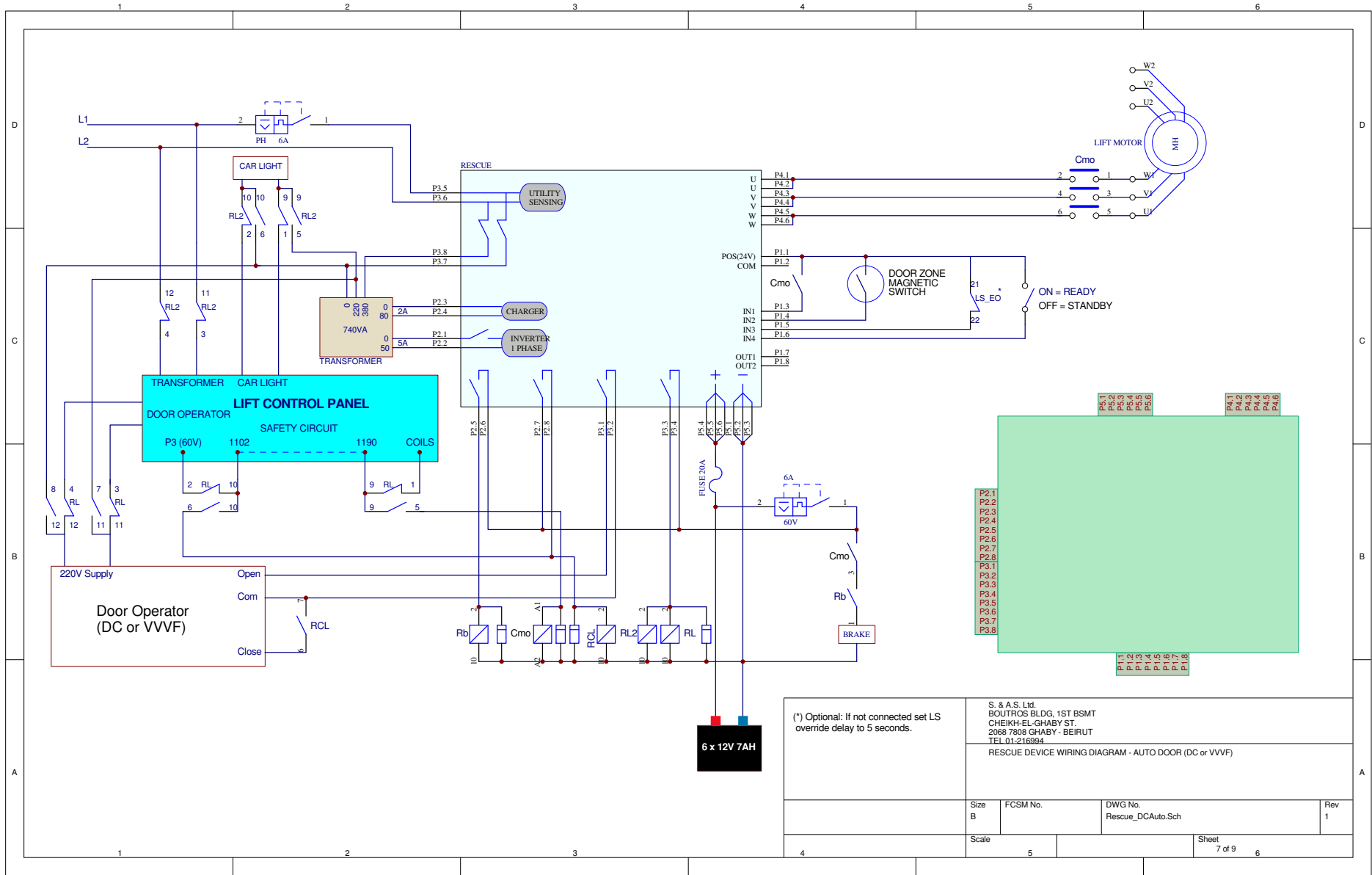

(\*) Optional: If not connected set LS override delay to 5 seconds.

S. & A.S. Ltd.  
 BOUTROS BLDG. 1ST BSMT  
 CHEIKH-EL-GHABY ST.  
 2068 7808 GHABY - BEIRUT  
 TEL 01-216994

RESCUE DEVICE WIRING DIAGRAM - AUTO DOOR (DC or VVVF)

Size B	FCSM No.	DWG No. Rescue_DCAuto.Sch	Rev 1
Scale			Sheet 7 of 9

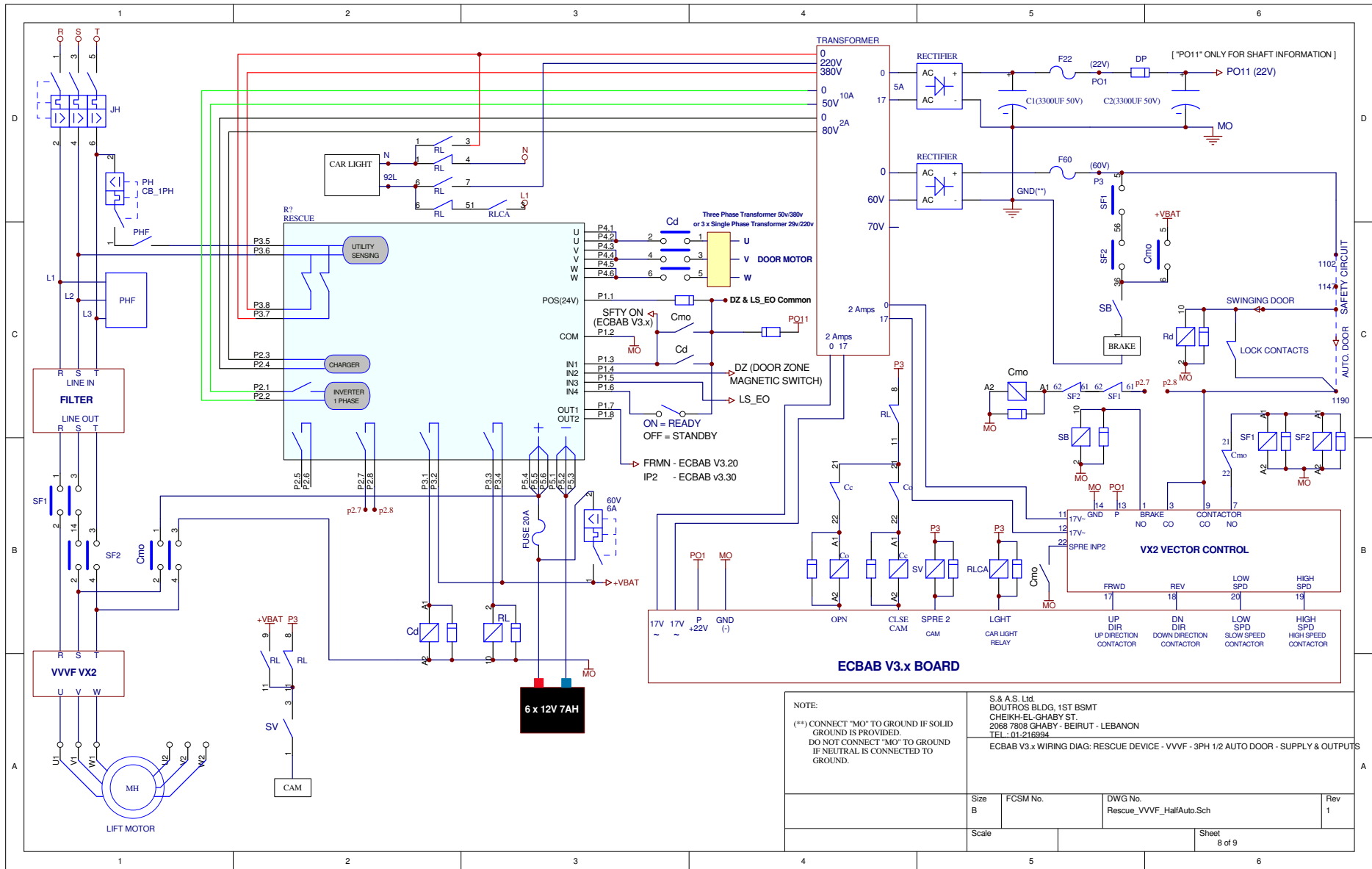

NOTE:  
 (\*\*\*) CONNECT "MO" TO GROUND IF SOLID GROUND IS PROVIDED.  
 DO NOT CONNECT "MO" TO GROUND IF NEUTRAL IS CONNECTED TO GROUND.

S & A.S. Ltd.  
 BOUTROS BLDG. 1ST BSMT  
 CHEIKH-EL-GHABY ST.  
 2068 7808 GHABY - BEIRUT - LEBANON  
 TEL : 01-216994

ECBAB V3.x WIRING DIAG: RESCUE DEVICE - VVVF - 3PH 1/2 AUTO DOOR - SUPPLY & OUTPUTS

Size B	FCSM No.	DWG No. Rescue_VVVF_HalfAuto.Sch	Rev 1
Scale			Sheet 8 of 9

